

Handbook for Vaccine & Cold Chain Handlers



Handbook for **Vaccine & Cold Chain Handlers**

2010

Department of Health & Family Welfare
Ministry of Health and Family Welfare
Government of India



Contents

	Page No.
Figures	v
Tables	vi
Acknowledgments	vii
Abbreviations	ix
Chapter 1: Introduction	1
1.1 Background.....	2
1.2 Importance of Cold Chain and Vaccine Logistics Management.....	3
1.3 Objectives of the Handbook	4
1.4 Vaccine Preventable Diseases, Vaccines and National Immunization Schedule ..	5
1.5 Vaccine Safety and Potency	7
Chapter 2: Cold Chain System	9
2.1 Cold Chain	10
2.2 Safeguarding Vaccines	11
2.3 Monitoring of Cold Chain	12
Chapter 3: Cold Chain Equipment	15
3.1 Electric Cold Chain Equipments.....	16
3.2 Non-Electrical Cold Chain Equipments	32
Chapter 4: Temperature Monitoring	41
4.1 Storage Temperatures	42
4.2 Measuring and Recording of Temperatures	42
4.3 Recording & Monitoring of Storage Temperature	44
Chapter 5: Insulated Vaccine Van	47
Chapter 6: Maintenance of the Cold Chain Equipments	49
6.1 Cold Chain Maintenance System.....	50
6.2 Terminologies Related to Cold Chain Maintenance System	50
6.3 Float Assembly (Similar to a Spare Wheel)	52

6.4	Manpower Deployment.....	52
6.5	Preventive Maintenance of ILR/Deep Freezer	53
6.6	Trouble Shooting.....	56
6.7	How to Avoid Vaccines from Freezing.....	56
6.8	Shake Test.....	58
6.9	How to Maintain a Vaccine Carrier/Cold Box.....	58
Chapter 7: Vaccine Management: Storage & Distribution		59
7.1	Vaccine Storage.....	60
7.2	Management of Vaccines and Logistics at State, District and PHC Levels.....	61
7.3	Distribution of Vaccines and Logistics.....	63
7.4	Distribution of Vaccines from PHC.....	70
7.5	Sub-Centre/Village/Session Level	73
7.6	Alternate Vaccine Delivery System (AVDS).....	73
7.7	Improving Vaccine Use and Reducing Wastage	75
Chapter 8: Contingency Plans for Emergency – Alternative Storage Arrangement		77
Chapter 9: Responsibilities of Cold Chain Handlers and Medical Officer		81
9.1	Responsibilities of Cold Chain Handlers	82
9.2	Responsibilities of Medical Officer of PHC/CHC.....	83
Chapter 10: Facilitator Guide.....		85
10.1	Introduction	86
10.2	Suggested Guidelines for Cold Chain Handlers Training	86
10.3	Pre-Training Preparation Check List	86
10.4	List of Equipments and Supplies Required During Training	87
10.5	Tentative Programme for Vaccine & Cold Chain Handlers Training (Use Session Sequence as per Book Chapter)	88
10.6	Conducting Training Sessions	90
10.7	Role Play 1 (Script).....	93
10.8	Pre and Post Evaluation Questionnaire.....	95
References.....		98

Figures

	Page No.
1. Vaccine Production & Distribution in India	3
2. Cold Chain System.....	10
3. Heat Sensitivity	11
4. Freezing Sensitivity.....	11
5. Usable & Un-Usable Stages of VVM	13
6. WIC.....	16
7. Deep Freezer.....	17
8. Ice Lined Refrigerators.....	18
9. Components of ILR	19
10. Storage of Vaccines in ILR.....	20
11. Domestic Refrigerator.....	21
12. Solar Refrigeration System	23
13. Front View of Normal Voltage Stabilizer	26
14. Rear View of Normal Voltage Stabilizer	26
15. Control Panel D/F, MF Model.....	27
16. Control Panel ILR, MK Model	27
17. Control Panel DF for HBD Model	28
18. Control Panel ILR for HBC Model.....	29
19. Packing of Equipment for Transportation	30
20. Transport Equipment in Vertical Position	31
21. Space between Equipment and Wall	31
22. Cable and Socket.....	32
23. Cold Boxes.....	33
24. Vaccine Carrier	34
25. Ice Pack	36
26. Ice Pack Stacking in Deep Freezer	37
27. Ice Packs Conditioning.....	39
28. Conditioned Ice Packs.....	39
29. Dial Thermometer	42
30. Stem Thermometer.....	43
31. Electronic Data Logger	43
32. Freeze Indicator	43

33.	Temperature Record Book.....	45
34.	Insulated Vaccine Van	48
35.	Vaccine & Logistics Supply Voucher	64
36.	Vaccine & Logistics Indent Form.....	65
37.	Stock Register.....	66
38.	Vaccine & Logistics Issue Register	67
39.	AVD Plan	74
40.	Emergency Plan for Vaccine Store	79

Tables

	Page No.	
1.	Number of Vaccine Stores in the Country as on August 2009	3
2.	Vaccine and Vaccine Preventable Diseases.....	5
3.	Vaccine Storage with Duration at Different Level.....	61
4.	Alternatives for Emergency Situations	80

Acknowledgements

The handbook for vaccine and cold chain handlers was prepared with technical contributions from Ministry of Health and Family Welfare, Government of India, UNICEF, WHO/NPSP, MCHIP, State Immunization officers, State Cold Chain Officers and other development partners.

Generous financial support from Norway India Partnership Initiative (NIPI) facilitated development of this handbook.

Abbreviations

AEFI	Adverse Event Following Immunization
A	Ampere
AD Syringe	Auto Disable Syringe
AVD	Alternate Vaccine Delivery
cm	Centimeter
CFC	Chloro-Flouro-Carbon
CCO	Cold Chain Officer
Cum	Cubic Meter
DF	Deep Freezer
DVS	Divisional Vaccine Store
°C	Degree Celsius
D.G. Set	Diesel Generator Set
EEFO	Early to Expire First to Out
FIFO	First-In-First Out
GSP	Good Storage Practice
GMSD	Government Medical Store Depot
Hq.	Head Quarter
Hrs	Hours
ILR	Ice Lined Refrigerator
ISI	Indian Standard Institute
IEC	Information Education and Communication
IU	International Unit
IM	Intra Muscular
KVA	Kilo Volt Ampere
MOI/c	Medical Officer In-Charge
ml	Milliliter
mm	Millimeter
NE	North Eastern
OPV	Oral Polio Vaccine
PW	Pregnant Women
PHC	Primary Health Center
PPI	Pulse Polio Immunization
Sq. m	Square Meter
SOP	Standard Operating Procedure
SC	Sub-Center
UT	Union Territories
UIP	Universal Immunization Programme
VVM	Vaccine Vial Monitor
V	Volt
WIC	Walk in Cooler
WIF	Walk in Freezer

Chapter 1

Introduction



1

1.1 Background

1.2 Importance of Cold Chain and Vaccine Logistics Management

1.3 Objectives of the Handbook

1.4 Vaccine Preventable Diseases, Vaccines and National Immunization Schedule

1.5 Vaccine Safety and Potency

1.1 Background

Immunization is one of the most well-known and effective methods of preventing childhood diseases. With the implementation of Universal Immunization Programme (UIP), significant achievements have been made in preventing and controlling the Vaccine Preventable Diseases (VPDs). Immunization has to be sustained as a high priority to further reduce the incidence of all VPDs, control measles, eliminate tetanus and eradicate poliomyelitis.

India has one of the largest Universal Immunization Program (UIP) in the world in terms of quantities of vaccines used, number of beneficiaries (27 million infants and 30.2 million pregnant women) covered, geographical spread (29 States and 6 Union Territories) and manpower involved. India spends more than Rs. 2000 crores every year in immunization program (including polio eradication) to immunize children against vaccine preventable diseases including polio eradication program.

Under UIP, all the children in the entire country are protected against the 6 deadly Vaccine Preventable Diseases (VPD) namely Tuberculosis, Diphtheria, Tetanus, Pertussis, Polio and Measles. Additionally Hepatitis B and Japanese Encephalitis (JE) vaccine have been introduced in selected districts/cities/States/UTs. Immunization services are provided through vast health care infrastructure consisting of district hospitals, community health centers (CHC), primary health centres (PHC) and sub-centers.

Since the inception of UIP, a wide network of cold chain stores have been created consisting of Government Medical Supply Depots (GMSD), State,

Figure 1: Vaccine production and distribution in India

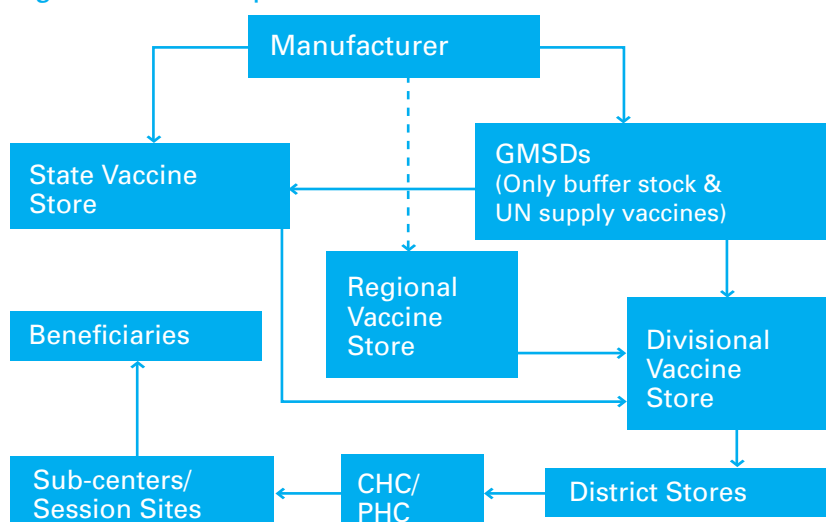

Table 1: Number of vaccine stores in the country as on August 2009

Store level	Number
GMSDs	4
State Vaccine Stores	35
Regional Vaccine Stores	20
DVS	96
District Stores	626
CHC/PHC	26439

Regional/Divisional Vaccine stores, District and PHC/CHC vaccine storage points. Cold chain network in the country has been the backbone to ensure that right quantity and right quality of vaccine reaches the target population. The logistics has been managed through the cycle of storing and transporting vaccine through pre-defined network. The vaccine typically arrives at the primary stores called Government Medical Store Depots (GMSDs) where stock is maintain for maximum of 3 months. There are 4 GMSDs in the country (Karnal, Chennai, Mumbai and Kolkata). Vaccines then are transported to state vaccine stores and through divisional and district vaccine store it reaches the last storage point of CHC or PHC. Figure 1 shows the flow of vaccine through the network.

1.2 Importance of Cold Chain and Vaccine Logistics Management

One of the important elements for improving the immunization is cold chain and vaccine logistics management which is backbone of immunization programme. Cold Chain and vaccine management are the left and right hands of immunization programme. As a cold chain handler, you play a very important role in improving the Immunization coverage of mothers & children by providing safe and potent vaccines and logistics in time.

This Hand Book has been written for the Cold Chain & Vaccine Handlers at State, Regional, Divisional, District

and PHC levels. The cold chain handler is a key person for maintenance of cold chain & vaccine management and responsible for safe storage of vaccine under Universal Immunization programme.

The Cold Chain in immunization programme had changed significantly in last seven to eight years, which includes replacement of CFC to Non-CFC refrigerants, inclusion of new vaccines (Hep. B and JE), new cold chain equipments supplied by new manufacturers. Such changes underscore the need to update the cold chain module.

1.3 Objectives of the Handbook

The main objective of this handbook is to enable the cold chain & Vaccine handler to efficiently manage the cold chain and vaccine management system. It provides the handlers a technical and practical guidance that they must weigh to devise the best solution for their circumstances. It is an effort to illustrate how technical and operational issues can be addressed in the field in order to keep vaccines potent and of good quality.

The learning objectives of handbook are:

- To list essential elements of the cold chain & vaccine management system and its importance in the immunization programme.
- To describe the cold chain equipment & its maintenance at various levels in the district.
- To state the follow up measures in case of breakdown of equipment and list alternative storage arrangement in emergency situations.
- To illustrate storage and correct stocking of vaccines, ice packs, diluents at district and block health facilities and during the transport.
- To explain how to manage the stocks and improve vaccine use at PHC and SC level.
- To enumerate the responsibilities of cold chain handlers in monitoring of the cold chain system.
- To discuss factors affecting potency of vaccines and precautionary measures to ensure the potency of vaccines.

1.4 Vaccine Preventable Diseases, Vaccines and National Immunization Schedule

There are certain diseases, which can be prevented through vaccination. The vaccine preventable diseases against which vaccines are currently available under Universal Immunization Program are:

- Polio
- Measles
- Pertussis (Whooping Cough)
- Diphtheria
- Tetanus
- Tuberculosis (T.B.)
- Hepatitis B in selected states, districts and cities
- JE – in endemic districts

New vaccines proposed are MR and Pentavalent (DPT+HepB+Hib)

Name of Vaccine	Prevention of Diseases
MR	Measles and Rubella & Congenital Rubella Syndrome
Pentavalent	Diphtheria, Pertussis (Whooping Cough), Tetanus, hepatitis B and Haemophilus influenzae B

New vaccines under consideration are:

- Rubella (as Measles – Rubella (MR) vaccine in some states).
- H. influenzae B – Hib (as liquid pentavalent vaccine consisting of DPT + Hepatitis B + Hib) in some states.

To prevent the above-mentioned diseases, following vaccines are being provided to infants, children and pregnant women under universal immunization program.

Table 2: Vaccine and vaccine preventable diseases

Name of Vaccine	Prevention of Diseases
Oral Polio Vaccine (OPV)	Polio
Measles	Measles
DPT	Diphtheria, Pertussis (Whooping Cough) and Tetanus
BCG	Tuberculosis
Hep. B	Hepatitis – B
TT	Tetanus
JE	Japanese Encephalitis

National Immunization Schedule for Infants, Children and Pregnant Women

Vaccine	When to give	Dose	Route	Site
For Pregnant Women				
TT-1	Early in pregnancy	0.5 ml	Intra-muscular	Upper Arm
TT-2	4 weeks after TT-1*	0.5 ml	Intra-muscular	Upper Arm
TT- Booster	If received 2 TT doses in a pregnancy within the last 3 yrs*	0.5 ml	Intra-muscular	Upper Arm
For Infants				
BCG	At birth or as early as possible till one year of age	0.1ml (0.05ml until 1 month age)	Intra-dermal	Left Upper Arm
Hepatitis B	At birth or as early as possible within 24 hours	0.5 ml	Intra-muscular	Antero-lateral side of mid-thigh
OPV-0	At birth or as early as possible within the first 15 days	2 drops	Oral	Oral
OPV 1,2 & 3	At 6 weeks, 10 weeks & 14 weeks	2 drops	Oral	Oral
DPT1,2 & 3	At 6 weeks, 10 weeks & 14 weeks	0.5 ml	Intra-muscular	Antero-lateral side of mid thigh
Hepatitis B 1, 2 & 3**	At 6 weeks, 10 weeks & 14 weeks	0.5 ml	Intra-muscular	Antero-lateral side of mid-thigh
Measles	9 completed months-12 months. (give up to 5 years if not received at 9-12 months age)	0.5 ml	Sub-cutaneous	Right upper Arm
Vitamin A (1stdose)	At 9 months with measles	1 ml (1 lakh IU)	Oral	Oral
For Children				
DPT booster	16-24 months	0.5 ml	Intra-muscular	Antero-lateral side of mid-thigh
OPV Booster	16-24 months	2 drops	Oral	Oral
Japanese Encephalitis***	16-24 months	0.5 ml	Sub-cutaneous	Left Upper Arm
Vitamin A***** (2nd to 9th dose)	16 months with DPT/OPV booster Then, one dose every 6 months up to the age of 5 years.	2 ml (2 lakh IU)	Oral	Oral
DPT Booster	5-6 years	0.5 ml.	Intra-muscular	Upper Arm
TT	10 years & 16 years	0.5 ml	Intra-muscular	Upper Arm
<p>* Give TT-2 or Booster doses before 36 weeks of pregnancy. However, give these even if more than 36 weeks have passed. Give TT to a woman in labour, if she has not previously received TT.</p> <p>** In select states, districts and cities.</p> <p>*** SA 14-14-2 Vaccine, in select endemic districts after the campaign.</p> <p>**** The 2nd to 9th doses of Vitamin A can be administered to children 1-5 years old during biannual rounds, in collaboration with ICDS.</p>				
<p>Proposed Changes in the National Immunization Schedule: 2009-10</p> <ul style="list-style-type: none"> DPT and HepB vaccines at 6, 10 and 14 weeks to be replaced by DPT-HepB-Hib (Pentavalent) vaccine. In select well-performing states, MR to be given with DPT Booster at 16-24 months (Dose: 0.5 ml; Route: Sub-Cutaneous; Site: Right Upper Arm). 				
<p>Vaccination schedule may get modified if new vaccines are introduced in future under Universal Immunization Programme.</p>				

1.5 Vaccine Safety and Potency

It is a universal fact that all vaccines are sensitive to heat & light and some are sensitive to freezing. Therefore, vaccines should be kept at an appropriate temperature range from the time of manufacture to the time of use. A vaccine must have two characteristics, one is **safety** and other is **potency**. The vaccines lose their potency if they are not stored or transported at an appropriate temperature and condition (light sensitive vaccines-cool, dark condition). Keeping vaccines at the right temperature is not an easy task, but the consequences of not doing so can be disastrous.

Once vaccine potency is lost, it cannot be regained. The damaged vaccines must be destroyed. And it leads to inadequate vaccine stocks and wastage of expensive vaccines. Moreover, children and women who receive a vaccine that is not potent are not protected.

Potency of the vaccine should be maintained to get optimum benefit of immunization programme.

The safety of the vaccine is linked to the adverse event following immunization programme. Hence all attempts should be taken to retain the safety of the vaccine.

Chapter 2

Cold Chain System



2

2.1 Cold Chain

Cold Chain is a system of storing and transporting vaccine at the recommended temperature range from the point of manufacture to point of use.

In order to provide potent and effective vaccine to the beneficiaries a vast cold chain infrastructure is required, which should have a network of Vaccine Stores, Walk-in-coolers (WIC), Walk-in-freezers (WIF), Deep Freezers (DF), Ice lined Refrigerators (ILR), Refrigerated trucks, Vaccine vans, Cold boxes, Vaccine carriers and icepacks from national level to states up to the out reach sessions.

The cold chain system and vaccine flow in the country:- The vaccines are transported from the manufacturer through air transport under the temperature range of 2-8°C to the primary vaccine stores (GMSDs/State head quarter).

2.1 Cold Chain

2.2 Safeguarding Vaccines

2.3 Monitoring of Cold Chain

Figure 2: Cold chain system

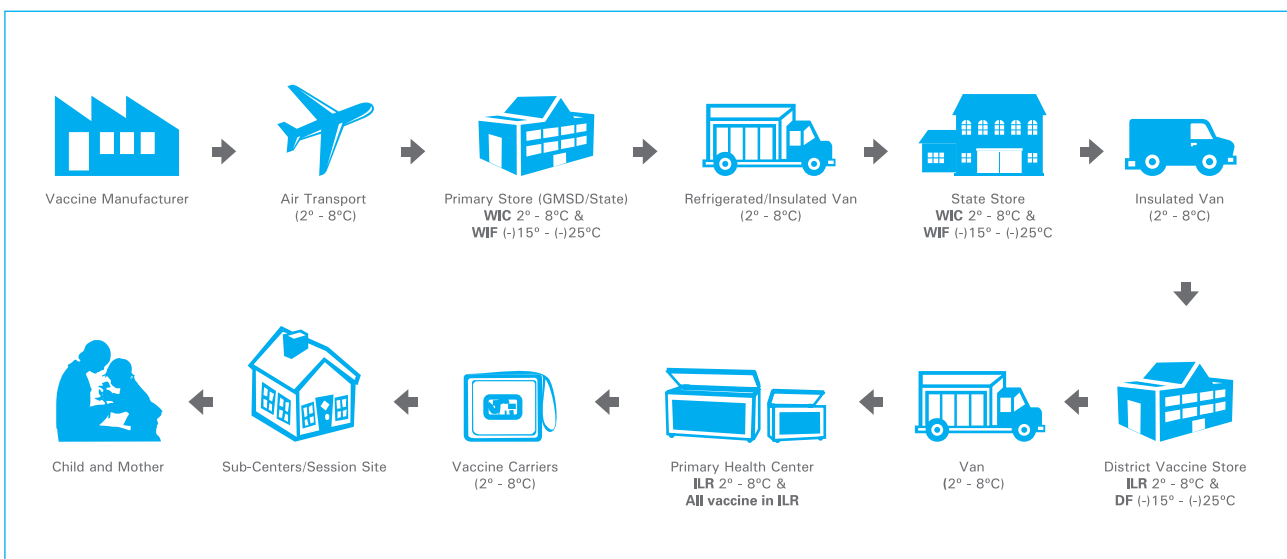

2.2 Safeguarding Vaccines

The key elements of the cold chain are:

- **Personnel:** to manage vaccine storage and distribution.
- **Equipment:** to store and transport vaccine.
- **Procedures:** to ensure that vaccines are stored and transported at appropriate temperatures.

Vaccines lose their potency due to either exposure to

- Excessive heat or
- Excessive cold (some vaccines like DPT, TT, Hep. B)
- Light (some vaccines like BCG and measles)

The physical appearance of the vaccine may remain unchanged even after it is damaged which is permanent. Chart below shows the thermo-sensitivity of the vaccines used in UIP.

Evidence suggests that excessive cold or freezing could occur at any level and the vaccine handlers should take precautionary steps to prevent vaccine freezing and discard vaccines that are damaged due to freezing.

Damage due to light

BCG and Measles vaccines are also light sensitive, which is why they are supplied in amber-colored vials. Therefore, they need to be kept away from light.

Figure 3: Heat sensitivity

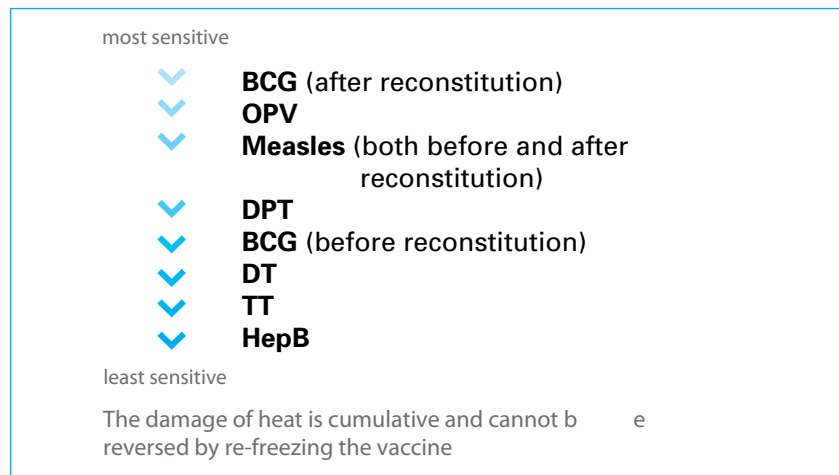
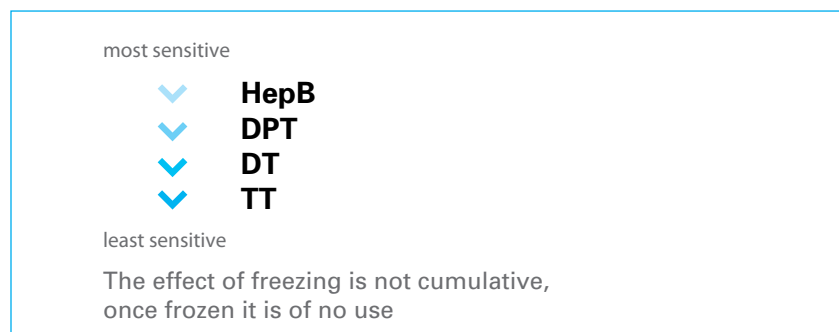

Figure 4: Freeze sensitivity



Key Points to Remember

- Cold Chain is a system of storing and transporting the vaccines at recommended temperatures from the point of manufacture to the point of use.
- It is crucial to maintain efficient cold chain right from the point of manufacture to its use among beneficiaries.
- Once vaccines lose their potency due to heat or freezing, they can no longer protect individuals from a disease and therefore are useless.
- Vaccine-potency once lost cannot be restored.
- Never use damaged vaccines as it gives false sense of security to the beneficiaries and also affects credibility of the program adversely. Use of damaged vaccines does not protect the children. As a result, outbreak of vaccine preventable diseases could occur in future.
- Reconstituted BCG and Measles Vaccines should not be used beyond 4 hours from the time of its reconstitution. This increases chances of AEFIs.
- Reconstituted JE vaccine should not be used beyond 2 hours from the time of its reconstitution and should be kept at 2° to 8°C.
- **If not utilized completely, these reconstituted vaccines should be discarded within 4 hours in the case of BCG and Measles and within 2 hrs in case of JE vaccine.**

2.3 Monitoring of Cold Chain

What to monitor?

- Availability of cold chain equipments & its working.
- Supplies and smooth flow of vaccines.
- Storage temperature.
- Potency.

Any machinery functions well as long as it is effectively controlled and monitored by personnel. This is true for cold chain equipment as well. Cold chain system should be monitored regularly, to safeguard vaccines.

Vaccine Damage

The physical appearance of the vaccine may remain unchanged even after it is damaged. The loss of potency due to either exposure to heat or cold is permanent and can not be regained.

Heat Damage

All vaccines are damaged by temperatures more than +8°C, whether they are exposed to a lot of heat in a short time (e.g., as a result of keeping vaccine in a closed vehicle in the sun) or a small amount of heat over a long period (e.g., as a result of the frequent opening of lid of ILR).



Reconstituted BCG, measles and JE vaccines are the most sensitive to heat and light. Since these live vaccines do not contain preservatives, there is risk of contamination. Therefore, BCG and Measles should not be used after 4 hours of reconstitution and JE vaccine should not be used after 2 hrs of reconstitution.

Checking for heat damage: The Vaccine Vial Monitor (VVM): A VVM is a label containing a heat-sensitive material which is placed on a vaccine vial to register cumulative heat exposure over time.

The combined effects of time and temperature cause the inner square of the VVM to darken gradually and irreversibly. Before opening a vial, check the status of the VVM.

Does a VVM measure vaccine potency? No, the VVM does not directly measure vaccine potency but it gives information about the main factor that affects potency: heat exposure over a period of time. The VVM does not, however, measure exposure to freezing that contributes to the degradation of freeze-sensitive vaccines.

Figure 5: Usable & un-usable stages of the VVM

Usable Stages	Unusable Stages
	
<p>Reading the Stages of the VVM The inner square is lighter than the outer circle. If the expiry date has not been passed: USE the vaccine.</p>	<p>Discard Point: The color of the inner square matches that of the outer circle: DO NOT use the vaccine. If the color of the inner square is darker than the outer circle, DO NOT use the vaccine.</p>

Do not keep these in the cold chain

1. Any vials that are expired.
2. Frozen or with VVMs beyond the discard point.

They may be confused with those containing potent vaccines. Keep them in the red bag for disinfection and disposal.

Correct storage and use of diluents

Only use the diluents supplied and packaged by the manufacturer with the vaccine, since the diluents is specifically designed for the needs of that vaccine, with respect to volume, pH level and chemical properties.

The diluents may be stored outside the cold chain as it may occupy the space of ILR but keep diluents for at least 24 hours before use in ILR to ensure that vaccines and diluents are at +2° to +8°C when being reconstituted. Otherwise, it can lead to thermal shock that is, the death of some or all the essential live organisms in the vaccine. Store the diluents and droppers with the vaccines in the vaccine carrier during transportation. Diluents should not come in direct contact with the ice pack.

Chapter 3

Cold Chain Equipment



3

3.1 Electrical Cold Chain Equipments

3.2 Non-Electrical Cold Chain Equipments

The equipments for storage of vaccines must have recommended temperature conditions for vaccine-storage round the year. There are different equipments of different capacity for storage of vaccines at different levels. Some of the equipments are dependent on electric supply to maintain the recommended temperature, while others can maintain the desired temperature range even in the absence of power supply for a specific time period.

3.1 Electrical Cold Chain Equipments

3.1.1 Walk-in-Freezers (WIF)

These are used for bulk storage of OPV, and also to prepare frozen ice packs at state stores. They maintain a temperature around (-) 20°C. They are available in sizes of 16.5 Cum. and 32 Cum. These are provided with two identical cooling units and standby generator set. The Generator set starts automatically as soon as the power cuts off. An alarm system is also provided. As soon as the temperature crosses the safe range a hooter hoots loudly. Bulk quantities of ice packs are also made and stored in the Walk-in-Freezers.

Walk-in-Freezers are installed in all of the states and larger divisional head quarters.

3.1.2 Walk-in-Coolers (WIC)

These are used for bulk storage of vaccines at State and Regional/Divisional Stores. They maintain a temperature of +2°C to +8°C. They are available in sizes of 16.5 Cum. and 32 Cum. These are used for storage of large quantities of vaccines, like DPT, DT, TT, Measles, BCG, Hepatitis B. They have two identical cooling units and standby generator sets with automatic start and stop facilities. They are also provided with temperature recorder and alarm

Figure 6: WIC



systems. Once the temperature of WIC is more than +10°C, alarm system gets activated.

Walk-in Coolers are established at regional levels, which store vaccines for about 4-5 districts. WIC/WIF store vaccines of three months requirement and 25% buffer stock for the districts they cater.

Figure 7: Deep freezer



3.1.3 Deep Freezer

Deep Freezers with top opening lids have been supplied under the immunization programme.

The cabinet temperature is maintained between -15° to -25°C. This is used for storing of OPV (district level and above only) and also for freezing ice packs. In case of power failure, it can maintain the cabinet temperature in the range of -15° to -25°C for 18 & 26 hours at ambient temperatures of 42°C and 32°C respectively, **if not opened**. The deep freezers have vaccine storage capacity and ice pack freezing capacity. These are available in different sizes (Large and small) as under:

- DF (L): Model MF 314 - vaccine storage capacity 264 liters or 380 icepacks.
- DF (S): Model MF114 - vaccine storage capacity 72 liters or 130 icepacks.
- DF (L): Model HBD 286 - vaccine storage capacity 200 liters or 350 ice packs.
- DF (S): Model HBD 116 - vaccine storage capacity 80 liters or 140 ice packs.

The Deep Freezer is provided with special insulation, which helps in maintaining inside temperature in the range of (-) 25°C to (-) 15°C.

All districts have been provided 2-5 large deep freezers whereas most of the PHCs have been provided with one small deep freezer.

*Large deep freezers at **district headquarters** have been supplied for:*

- Storage of OPV
- Preparation of ice packs

*Small deep freezers at **PHC headquarters** have been supplied for:*

- Preparation of ice packs only

Note: All routine immunization vaccines including OPV/Measles should be stored only in ILR at PHC/CHC level for maximum period of one month.

Remember

Diluents should not be kept in deep freezers. These should be stored under temperature between +2° to +8°C at least 24 hours before use and should be transported along with the concerned vaccine as bundle.

The ILR lid should be opened only when required.

Hold over time of equipments

It is a time taken by the equipment to raise inside vaccine temperature at the time of power failure from its minimum temperature to 10°C, subject to the condition that the equipment is functioning well e.g. in the case of ILR, the minimum temperature is 2°C the time taken to reach 10°C from 2°C will be the hold over time of the ILR.

Hold over time depends on the following factors:

- Ambient temperature, more ambient temperature less will be the hold over time.
- Number of frozen Ice Packs inside the D/F.
- Frequency of opening of lid and use of basket.
- Quantity of vaccines kept inside with adequate space between the containers.
- Condition of icepacks inside Non electrical cold chain equipment.

3.1.4 Ice Lined Refrigerator (ILR)

These type of refrigerators are top opening because they can hold the cold air inside better than a refrigerator with a front opening. It can keep vaccine safe with as little as 8 hours continuous electricity supply in a 24-hour period. It is available in different sizes

- ILR- Model MK 304 of vaccine storage capacity 108 liters or 26000 to 30000 doses of mixed antigen.
- ILR- Model MK 144 of vaccine storage capacity 45 liters or 11000 to 13000 doses of mixed antigen.
- ILR- Model HBC 200 - vaccine storage capacity 100 liters or 24000 to 28000 doses of mixed antigen.
- ILR- Model HBC 70 - vaccine storage capacity 50 liters or 12000 to 14000 doses of mixed antigen.

The larger ILR is supplied to district headquarters and smaller ILR to PHC headquarters.

Inside the ILR there is a lining of water containers (ice packs or tubes) fitted all around the walls and held in place by frame. When the refrigerator is functioning the water in the containers freezes and if the electricity

Figure 8: Ice Lined Refrigerator



Figure 9: Components of Ice Lined Refrigerator

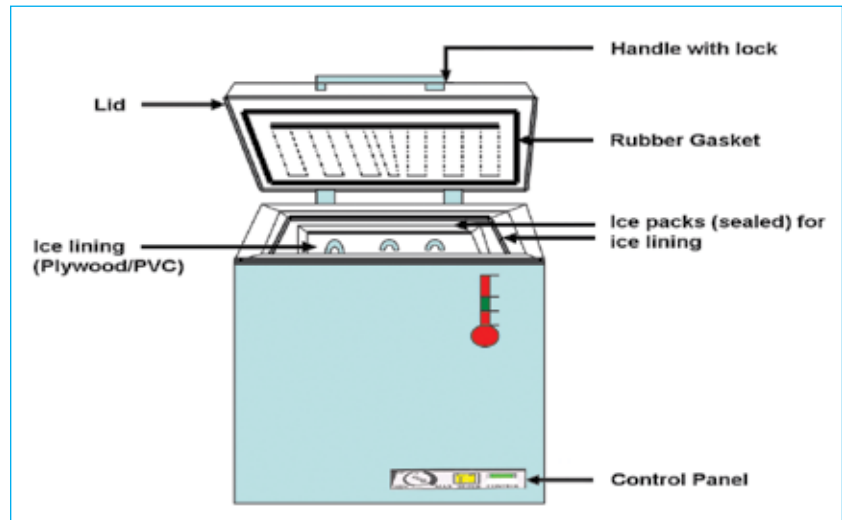

Remember

- Keep all vaccine in basket.
- Leave space between the vaccine boxes.
- Place a thermometer in the basket in between the vaccines.
- Keep freeze sensitive and closer expiry vaccines at TOP of the basket.
- Keep heat sensitive and further expiry date vaccines in the bottom of basket.

supply fails, then the ice lining maintains the inside temperature of the refrigerator at a safe level for vaccines. Therefore the temperature is maintained in ILR for much longer duration than in deep freezers and ILRs can keep vaccine safe.

The ILR has got two sections – the top and bottom. The bottom of the refrigerator is the coldest place and is shown as section A. The DPT, DT, TT and BCG vaccines should never be kept directly on the floor of the refrigerator as they can freeze and get damaged. The top section of the ILR is known as section B and it maintains the temperature of +2° to +8°C. All the vaccines should be kept in the basket provided with the refrigerator. OPV and Measles can be kept at bottom of the basket while BCG, DPT, DT and TT vaccines are kept in upper part of the baskets. In case basket is not available keep two layers of empty ice packs laid flat on the floor; do not keep the vaccines on the floor of the ILR.

Figure 10: Storage of vaccine in ILR

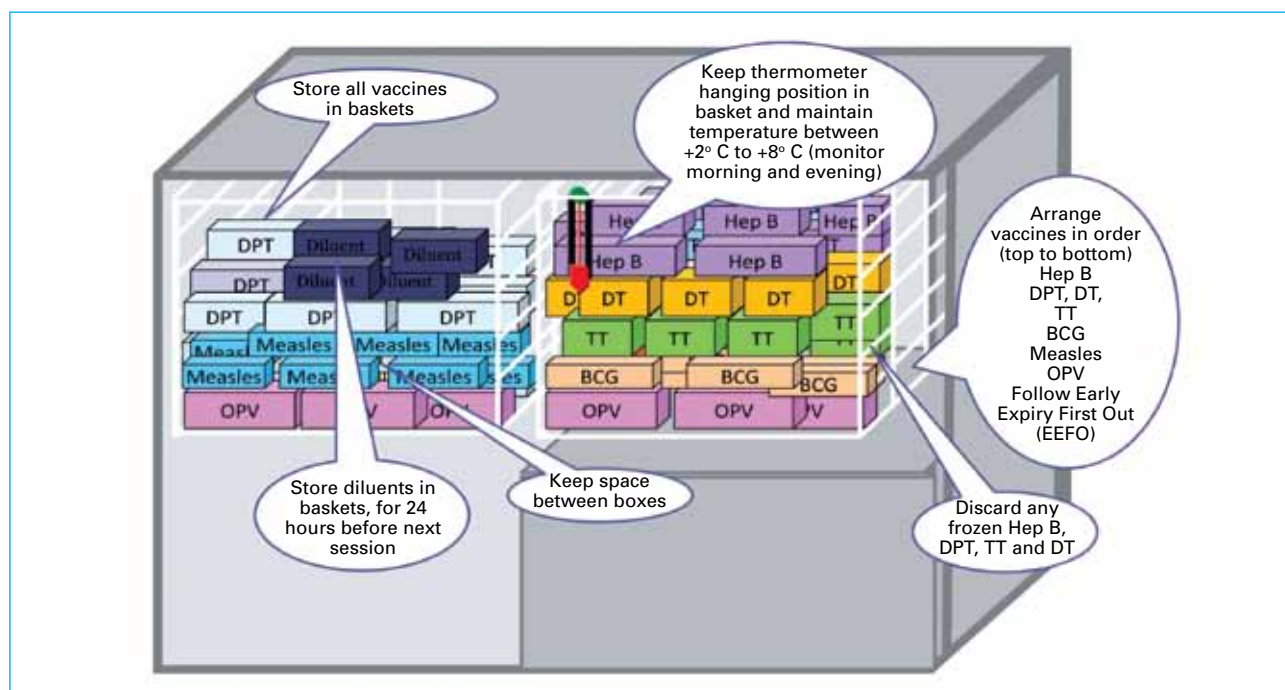

Hold over time of equipments

It is a time taken by the equipment to raise inside vaccine temperature at the time of power failure from its minimum temperature to 10°C, subject to the condition that the equipment is functioning well e.g. in the case of ILR, the minimum temperature is 2°C the time taken to reach 10°C from 2°C will be the hold over time of the ILR.

Hold over time depends on the following factors:

- Ambient temperature, more ambient temperature less will be the hold over time.
- Number of frozen Ice Packs inside the D/F.
- Frequency of opening of lid and use of basket.
- Quantity of vaccines kept inside with adequate space between the containers.
- Condition of icepacks inside Non electrical cold chain equipment.

Domestic refrigerators can be used for storage of vaccine at private clinics and nursing homes, provided continuous power supply is ensured and they are dedicated for storage of vaccines.

3.1.5 Domestic Refrigerators

Domestic refrigerators can also maintain the cabinet temperature between 2 to 8°C but they have hold over time of only 4 hours and capacity to store vaccines/ freeze icepacks is very limited. **Therefore, these refrigerators are not generally recommended for vaccine storage in the UIP.**

Figure 11: Domestic refrigerator

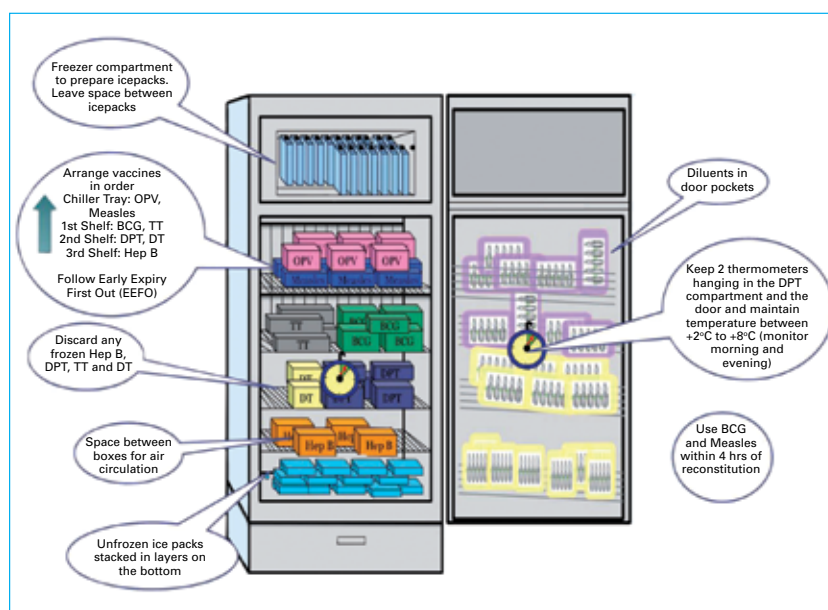

How to store vaccine in front load refrigerators (domestic refrigerators)

Refrigerators must be loaded correctly (as shown in figure no.10) to maintain the temperature of the vaccines and diluents.

If domestic refrigerator is used for universal immunization program to store Vaccines, diluents, and ice-packs then it should be exclusively used for the programme and no other drugs/Non-UIP vaccines should be stored.

Do not store other supplies such as drugs, ointment, serum, samples, food articles, drinks etc.

Do not put vaccines on the door shelves. The temperature in door shelves is too warm to store vaccines, and when the door is opened shelves are instantly exposed to room temperature.

Food and drinks should not be stored in a vaccine refrigerator.

Load a domestic refrigerator as follows:

1. Freeze and store ice-packs in the freezer compartment.
2. All the vaccines and diluents have to be stored in the refrigerator compartment.
3. Arrange the boxes of vaccine in stacks so air can move between them; keep boxes of freeze-sensitive vaccine away from the freezing compartment, refrigeration plates, side linings or bottom linings of refrigerators where freezing may occur.
4. Keep ice-packs filled with water on the bottom shelf and in the door of the refrigerator. They help to maintain the temperature inside in case of a power cut.
5. Load front-loading refrigerator with freezer on top as follows:
 - Measles, MR, MMR, BCG and OPV on the top shelf.
 - DPT, DT, TT, Hep B, Hib, and JE vaccines on the middle shelves; and.
 - Diluents next to the vaccine with which they were supplied.
6. Ice packs should be kept in the freezer compartment from left to right in vertical position to avoid leaking and with a space of at least 2mm. Ice packs should be taken out from the left.
7. Further expiry date vaccine should be kept in the back and closer expiry date vaccine in front. A suitable space is required in between two vaccine boxes.
8. Unfrozen ice-packs should be kept on the bottom.

3.1.6 Solar Refrigerators

A solar refrigerator operate on the same principle as normal compression refrigerators but incorporate low voltage (12 or 24V) DC compressors and motors, rather than mains voltage AC types. A photovoltaic refrigerator has higher levels of insulation around the storage compartments to maximize energy efficiency, a battery or number of batteries depending upon the size of panel for electricity storage, a battery charge regulator and a controller that converts the power from the battery to DC form required by the compressor motor.

Figure 12: Solar refrigeration system

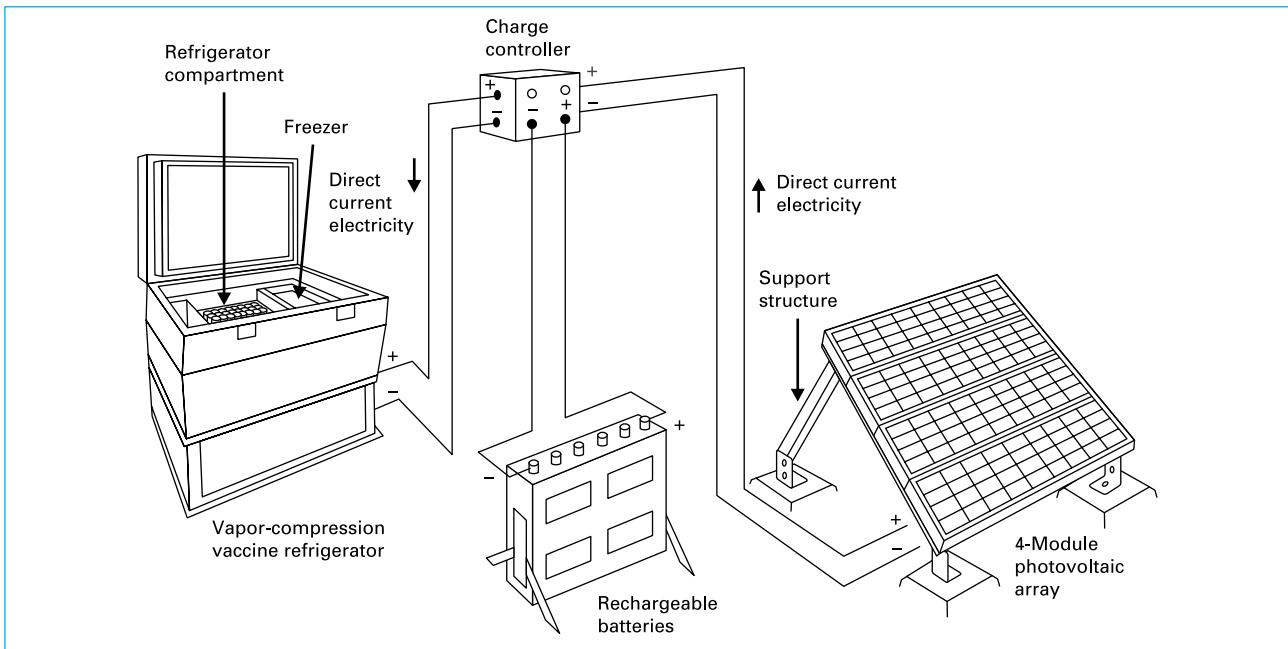

3.1.6.1 Components of solar refrigerator

1. Vaccine refrigerator/freezer: It is a refrigerator cum freezer having basket for storing of vaccine and freezing of ice packs. It has two separate compartments for vaccine storage maintaining temperature 2-8°C and freezing of ice packs of the temperature range (-) 15 to (-) 25°C. It has two compressors (AC or DC) having refrigerant CFC free R-134a (normally DC compressors are provided). The system enables continuous operation of the refrigerator and freezer.

2. Photovoltaic array (Panel): It is fabricated with mono or multi-crystalline silicon with a support structure of MS galvanized or aluminum. Array structures are designed to withstand wind loads of +200 kg per square meter and shall be supplied with fixings for either ground or roof mounting.

3. Array-to-refrigerator cable: This is a cable connecting array (panel) to the control box of the refrigerator for the delivery of voltage.



4. **Charge regulator:** The Charge regulator controls the charge of the battery. It has cut-off point at low and high voltage and indicators for charging, under charging and over charging. It also has an alarm system in case of disconnection of battery/module.

5. **Batteries:** Batteries store the energy transferred from the solar power. It provides power to the compressor directly in the case of DC compressor or through inverter in case of AC compressors. The normal capacity of the batteries to store solar energy is 5 days.

3.1.6.2 How to maintain solar panel

Roof-top solar energy systems are NOT 'maintenance-free'!

Dirt, soot, smog, and bird-droppings on the module can reduce the efficiency (output) of the solar system and makes the panel output like a VERY CLOUDLY DAY.

Do you know

Shading of 10% of a module of the solar panel by dirt or bird dropping can reduce power out put by 50%.

Solar system gives more power in hot sunny days in comparison to cloudy days.

Panel installed in dirty areas requires frequent inspection & cleaning.

Cleaning a solar panel is not cosmetic. A panel needs to be clean for it to operate at its rated capacity.

Steps

1. **Inspect** the solar panels on a periodic basis (frequency depends on location) to remove any debris and dirt.
2. **Clean** all module glass sun-surfaces with ambient -temperature de-mineralized cleaning solution (dishwashing soap), to prevent any glass-shock or hard-water spots.
3. **Remove** any bird dropping by brushing with soft fiber brush.
4. **Inspect** modules for signs of degradation such as color changes, fogged glazing, de-lamination, warping, or water leaks (apply sealant if required), cracked glazing, and/or bent frames.
5. **Ensure** all connections are tight.
6. **Inspect** exposed wiring for rodent & other damage.
7. **Check** for rust, galvanic corrosion, and electrolysis.
8. **Check** and adjust the tilt angle by the technician after every six month depending upon the Sun position (lower or high in the sky).

3.1.6.3 How to maintain solar batteries

Batteries are the most important component in the solar battery system.

Two types of batteries are in use.

1. Lead acid, long life, deep cycle battery
2. Maintenance free sealed batteries

Maintenance free sealed batteries are preferred as it requires minimal maintenance and environmental friendly as compared to lead acid batteries. Average shelf life of a battery is 2-3 years and needs periodic replacement.

Warning

Wear hand gloves, goggles or safety glasses when working with your batteries.

The battery acid is dangerous. Keep a box or bag of baking soda on and to spread on battery acid spills.

Adding water to sealed batteries can destroy battery.

Steps

1. Check the battery terminals and lugs periodically (at least once in a week).
2. Prevent corrosion with a sealant. Use petroleum jelly to prevent corrosion. Apply the jelly or sealant to terminals before assemble the battery bank. Otherwise, the sealant will not reach all the nooks and crannies, and terminals and lugs will corrode.
3. Keep batteries at even cool temperature. The idle ambient temperature for getting highest efficiency of a battery is 21 to 24°C.
4. Check the water levels of the batteries in every cell after every 6 months. All the cells in your flooded batteries must be covered by water. Use distilled or deionized water to top up. Do not overfill your flooded batteries.

3.1.7 Automatic Voltage Stabilizer

The function of the voltage stabilizer is to monitor the range of fluctuations in the main voltage of 90-280 V and maintain voltage in a required range of 220 + 10 V.

Types of voltage stabilizers

Three types of voltage stabilizers are provided in the country by Government of India:

1. Normal Voltage stabilizers: The voltage range: 150 – 280 V.
2. Low range voltage stabilizers: voltage range: 110 – 280 V.
3. Low range stabilizers for specific areas: 90 – 280 V.

Stabilizers should be installed as per the input voltage available.

Electrical cold chain equipment should never be installed without a voltage stabilizer.

- Every refrigeration unit must be connected to stabilizer.
- Only in emergency, one stabilizer per two small equipments is acceptable.
- Extended rating of 90 to 280 V recommended in the areas where problem of low voltage supply is exists.
- **Proper earthing** should be available and connected.
- Emphasise on repairing stabilizers immediately. Local help can be sought. Identify authorized and qualified service provider.
- No electrical cold chain equipment should be operated without stabilizer and by-passing of stabilizer must not be done. Whenever the stabilizer is out of order two small equipments can be connected with single stabilizer. Switch off Deep Freezer in emergency and operate ILR. Meanwhile get the stabilizer repaired.
- Include status of stabilizer in monthly report, ***it is an important part of cold chain equipment.***

Figure 13: Front view of normal voltage stabilizer

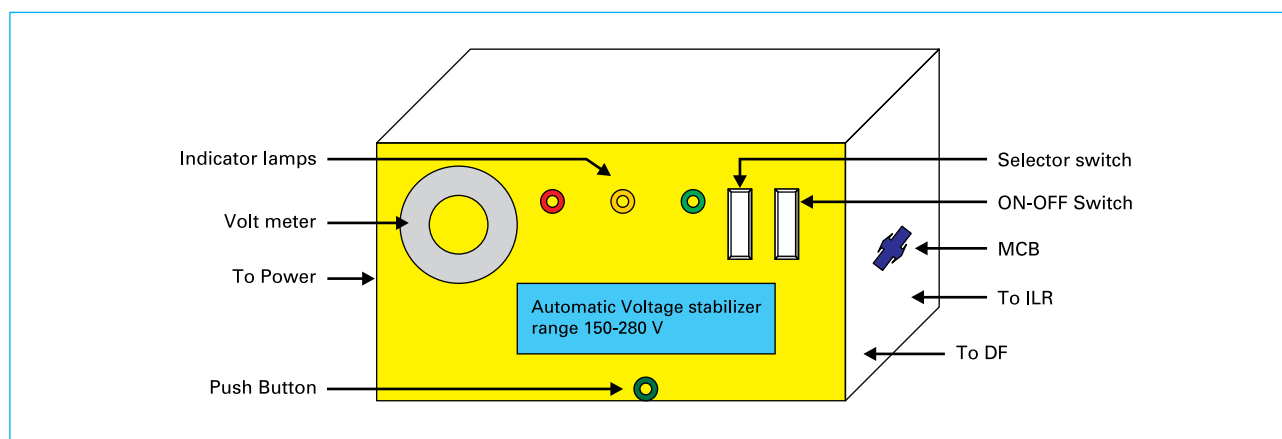
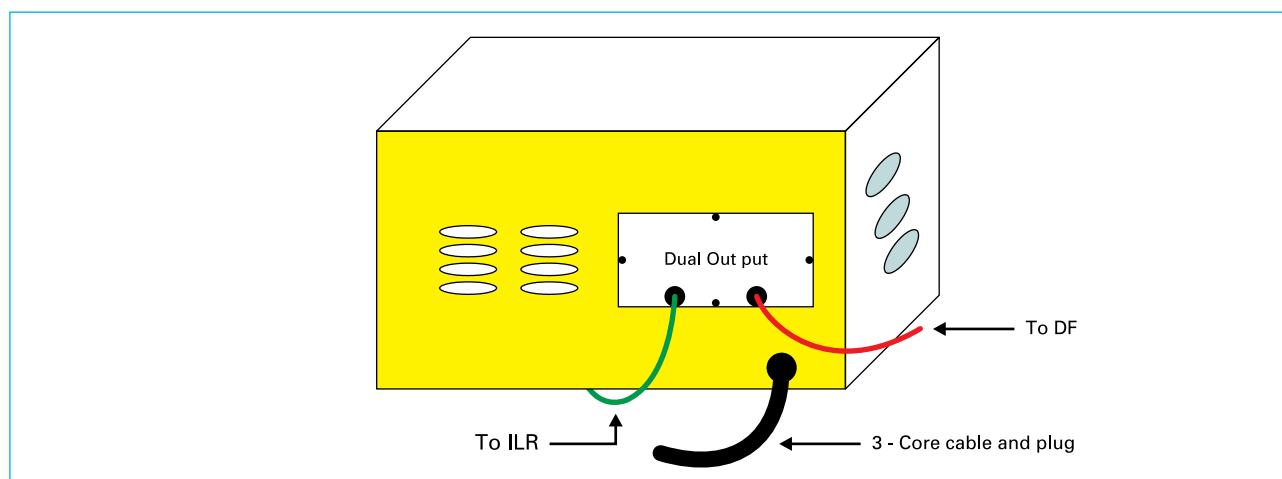

Figure 14: Rear view of normal voltage stabilizer



Components of Voltage Stabilizer

1. Voltmeter:- displays input and output voltage.
2. Green light: displays status of power input.
3. Selector switch: used for selection for input and output display.
4. Miniature Circuit Breaker: Auto cut off at the time of overloading of cold chain equipment.
5. Delay Timer Push Button: Every voltage stabilizer has a delay timer of 2 to 9 minutes. When the power is cutoff and then resumed, the stabilizer supplies power after its delay period. The push button can be used for instant starting of equipment without delay period.

3.1.8 Control Panel

3.1.8.1 To monitor the cold chain, at the front right bottom side of the ILR and Deep Freezer a control panel is provided.

The MK and MF models of ILR/DFs control panel consists of thermostat, thermometer and indicator lamp (Green and Red).

- Green light indicates that power is available to the equipment.
- Red light indicates that inside temperature is not in safer range.
- **Thermostat** is a device for regulating the temperature of a system so that the system's temperature is maintained near a desired set point temperature.
- Thermometer shows the inside temperature of the equipments.

Figure 15: Control panel deep freezer MF model



Figure 16: Control panel ILR MK model



1. Deep Freezer

- a. Green light (indicator lamp)
- b. Red light (indicator lamp)
- c. Thermometer (Dial or digital type)
- d. Thermostat

2. ILR

- a. Green light (indicator lamp)
- b. Yellow switch (Super switch)
- c. Thermometer (Dial or digital type)
- d. Thermostat

Remember

- Glowing of green light does not ensure that the equipment is in running condition, always keep close watch on the inside temperature of vaccine stored in the equipment.
- Adjust thermostat only when inside vaccine temperature is not in the safe limit.
- The thermostat should be adjusted when the ambient temperature is lowest during 24hrs of the day.
- The temperature indicated by the panel thermometer is not the temperature of vaccine. Keep Stem thermometer in side the basket of the ILR and record temperature only through alcohol stem thermometer.

The functions of above mentioned components are:

1. **Green light:** It is an indicator lamp, which shows that electric power is available up to the equipment from stabilizer.
2. **Red light** indicates that the temperature inside the equipment is not in safe range.
3. **Thermometer** shows the inside bottom temperature of the equipment.
4. **Yellow switch** is a thermostat bye pass switch used when the ambient temperature is more than 45°C or requires lowering down inside temperature quickly.
5. **Thermostat:** It is used to monitor the inside temperature of the vaccine as under:
 - a. **When inside vaccine temperature is higher than required range:**

Rotate thermostat clock wise by 10 to 15° observe for 24 hrs. If the temperature comes in safe range leave as it is other wise rotate further by 10 degree and observe for another 24hrs. Use this trial and error method to set the thermostat to get temperature in the safe range.
 - b. **When inside vaccine temperature is lower than required range:**

Rotate thermostat anti-clock wise by 10 to 15 degrees. Observe for 24 hrs. If the temperature comes in safe range leave as it is other wise rotate further by 10 degrees and observe for another 24hrs. Repeat till you get the temperature in the safe range.

3.1.8.2 Control panels with multi features

In some models (HBC) of ILRs control panels have multi features such as alarm system, microprocessor display panel for cooling, frost, temperature out of the range, digital display of temperature, display of minimum and maximum temperature during last 24 hrs etc.

Figure 17: Control panel DF for HBD model



The HBD model control panel of deep freezer does not have red indicator and yellow switch indicates the power in the deep freezer. It has digital thermometer and thermostat knob which has similar function as indicated above. The knob of thermostat has 6 different positions. The cabinet temperature will reduce from "1" to "6" position by rotating clockwise. Digital thermometer will display the cabinet temperature.

Figure 18: Control panel ILR for HBC model

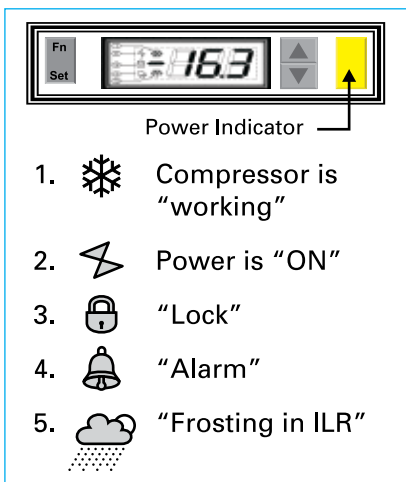

Note: The cabinet temperature of any location will not be same. The digital thermometer can only display one point temperature.

HBC model ILRs has a micro processor control system. It has following extra features:

1. Setting and locking of thermostat with display system.
2. Audio visual alarm when cabinet temperature is not in safe range.
3. Display when compressor is working.
4. Display when there is frosting in the ILR more than 0.3 mm and system requires defrosting.

Setting of temperature of microprocessor controlled ILR.

1. First unlock the panel by pressing 'Fn'+ 'Set' together for more than one second, there will be one sound from buzzer and display will show unlock condition by disappearing "🔒". All action/setting can be done only in unlock condition.
2. Press "set" and release it, the old setting value will flash. Now if "▼" button is pressed one time the value of set temperature will decrease by 0.1°C and similarly if "▲" button is pressed one time the set temperature will increase by 0.1°C. Press ▼ or ▲ buttons every time till you get the desired set temperature.
3. As soon as you reach the desired set temperature (4°C), press set button. The temperature will set within 5 seconds.

Alarm condition

The ILRs are set for the safe range of 2 to 8°C. As soon the cabinet temperature crosses the safe range an alarm will be sounded and display will flash 🔔.

The sound of alarm can be switched off by pressing any button of control panel **but the display 🚨 will not disappear as long as the cabinet temperature is in unsafe range.**

Checking of minimum and maximum temperature of the cabinet during last 24 hrs.

The HBC model ILRs have a function to check minimum and maximum temperature of the cabinet during last 24 hrs from the display panel.

The procedure of checking is as under:

1. Press “▲” button for 3 seconds, the display panel will flash the highest temperature of last 24 hrs at the point of time of checking.
2. Press “▼” button for 3 seconds, the display panel will flash the lowest temperature of last 24 hrs at the point of time of checking.

Display parameters

Display panel and keys: The panel will display 3 place digits of temperature such as 16.6 (the cabinet temperature will be +16.6°C), one minus sign (-) and 5 symbols for cooling, power, lock, alarm and frost in ILR. See figure no. 17 the flashing of symbols in the panel give following information.

- a. Flashing of symbol ❄️ means the compressor of the ILR is working and system has cooling effect.
- b. Flashing of symbol ⚡️ means the power is “ON” in the system. It has no concern with cooling and running of compressor.
- c. Display of symbol 🔒 shows that the system is in locked condition.
- d. Flashing of symbol 🚨 warns that the cabinet temperature is not in safe range.
- e. Display of symbol ☁️ warns that there is frosting in the cabinet for more than permissible limit and ILR/DF requires defrosting.

Figure 19: Packing of equipment for transportation

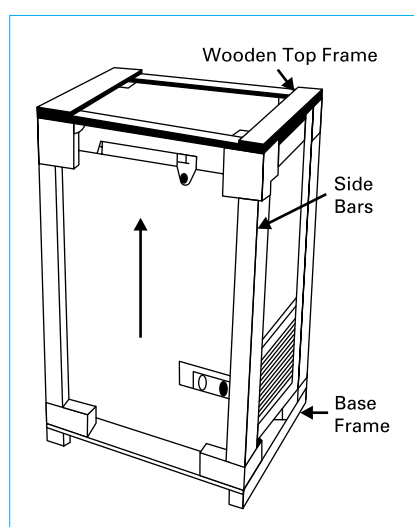

3.1.9 Installation of Equipment

Follow manufacturer’s instructions for installation scrupulously including selecting the safe site with proper ventilation and electric fittings as discussed hereafter.

3.1.9.1 Unpacking

Check the packing and the equipment before and after unpacking. A number of tools may be necessary for unpacking of equipment. Any damage or loss/irregularities should be reported to the relevant authorities.

Warning

Equipment/packing case should be stored vertically, as per arrow/symbol shown (↑) on the packing box failing which equipment may break down due to flow of oil in the condenser/evaporator or other damage may occur.

Figure 20: Transport equipment only in vertical position

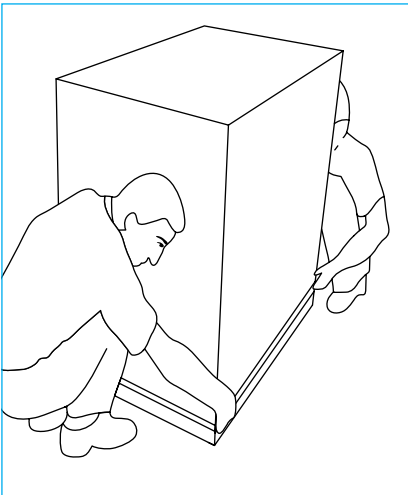

3.1.9.2 Installation of ILR/Deep Freezer/Refrigerator

Again the manufacturer's instructions for installation should be followed. This is important as most of the equipment come with a warranty from the manufacturers which remains effective only if the manufacturer's instructions are followed. Many of the equipment shall be installed by the manufacturer or his authorized representative in the presence of Govt. trained technician.

Remember

- Follow the guidelines of the manufacturer.
 - Transport the equipment only in the vertical position.
-
- Place the equipment in the spacious room (minimum size 3.5 m x 3.0 m) with good air ventilation through an exhaust fan. The ventilated air should be dry and without dust.

Figure 21: Space between equipment and wall

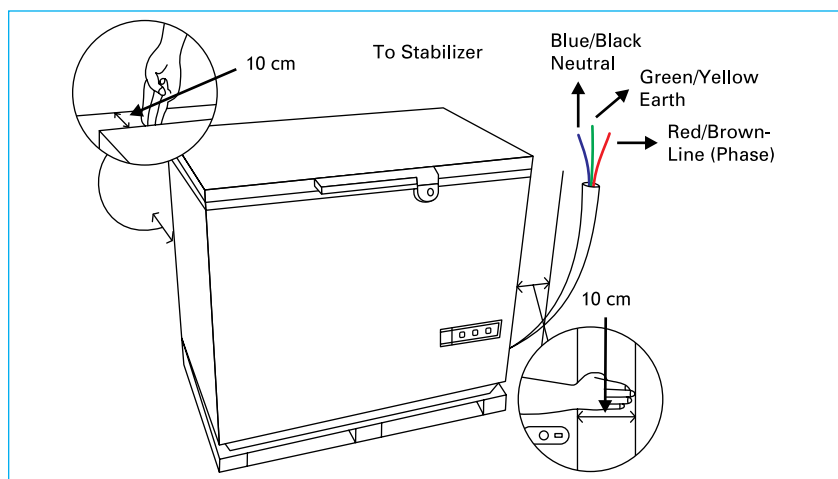

- The electric point should be nearest to the place where equipment is to be installed.
- There should not be direct Sun light on the equipment.
- Place the equipment in the leveled position.
- The equipments should be placed at least 10 cms away from the wall and other equipment.
- Connect voltage stabilizer for each equipments.
- The electric wiring should not be less than three core 7/20 cable of ISI marked.
- Three pin 15 ampere socket should be ISI marked and it should be nearest to the equipment.
- No extension cord should be used.
- Before starting the machine check the line for earthing and neutral.
- 3 pin 15 amps plug with ISI mark should be connected with the stabilizer.
- Connect both machines with stabilizer
 - Red or Brown wire – Phase/Line (L)
 - Blue or Black wire – Neutral (N)
 - Green or Yellow – Earth (E)
- Connect Plug with the socket.
- Rotate the thermostat up to Maximum.
- Switch "ON" the power supply.
- Allow to run the machine for 48 hrs. See the temperature become stable.
- Set the Thermostat at normal position.
- Load the machine through Ice packs/vaccine of desire quantity.

Figure 22: Cable and socket

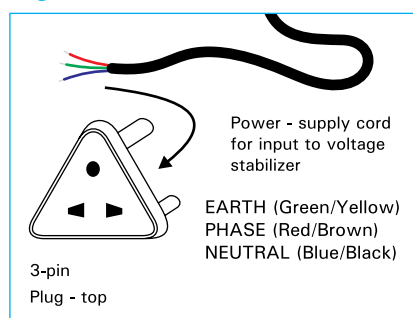

3.2 Non-Electrical Cold Chain Equipments

3.2.1 Cold Box

3.2.1.1 Cold boxes: Types and usage

Cold boxes are big insulated boxes. These are of different sizes- 5, 8, 20 and 22 liters with requisite number of ice packs. The 5 & 8 liters cold box can transport about 1500 & 2400 doses of mixed antigen vaccines respectively and 20-22 liters cold box has enough space to transport about 6000 – 6600 doses of mixed antigen vaccines respectively.

Cold Boxes are mainly used for transportation of vaccines. In emergency they can also be used to store vaccines as well as frozen ice packs. Before the



vaccines are placed in the cold boxes, conditioned ice packs should be placed at the bottom and sides of the cold box as per the diagram given on the top lid. The vaccines should be placed in cartons or polythene bags and then place in the cold box. The Vaccines are to be covered with a layer of conditioned ice packs and close the cold box. **The vials of DPT, DT, TT and Hep B vaccines should never be placed in direct contact with the ice packs** and they should be surrounded by OPV/ BCG/Measles vaccines.

Note that vaccines should be transported/stored in cold boxes only with sufficient number of conditioned ice packs.

Figure 23: Cold boxes



Uses

- Collect and transport large quantities of vaccines.
- Store vaccines for transfer up to five days, if necessary for outreach sessions or when there is power cut. The hold over time is more than 90 hours for 5 Liter and six days for 20 Liter cold box at +43°C ambient temperature, if the cold box is not opened at all.
- Store vaccine in case of breakdown of ILR.

3.2.1.2 How to pack?

- Place conditioned ice packs side by side against the inside walls and floor of the cold box as per the diagram given on the lid of the cold box.
- Stack vaccine and diluents in the box.
- Place packing material between DPT/DT/TT/Hep B vaccine and the ice pack to prevent vaccine from freezing.

- Place conditioned ice packs over the top of the vaccine and diluents.
- Place the plastic sheet to cover the ice packs kept on top to ensure full hold over time.
- Secure the lid tightly.
- Do not open the lid when not required.

Note: Ice packs are frozen in between -15°C to -25°C and therefore need to be conditioned before laying out in the cold boxes to prevent freezing of vaccines. To condition the hard frozen ice packs keep them out of deep freezer to allow them to 'sweat' and a cracking sound of water would be heard on shaking the icepacks. This will protect 'T' series vaccine from getting frozen. Use 'spacers' while using Cold Box so that 'T' series vaccines do not touch ice packs directly, otherwise keep 'T' series vaccines in small cardboard cartons.

3.2.1.3 How to keep Cold Boxes in good condition when not in use

- Clean and dry after every use.
- Do not keep any load over the cold box.
- The lid of the box should be kept unlocked and opened in the store while box is not in use. This will increase the life of the rubber seal.
- Examine inside and outside surface after every use for cracks.
- Check that the rubber seal around the lid is not broken; if broken, replace immediately.
- Knock and sunlight can cause cracks inside the wall and lid of the cold boxes.
- Lubricate hinges and locks routinely.

Note: Recently new models of cold boxes have been introduced. User should, therefore, be guided by the manufacturer's guidelines/ lay out plans of ice packs printed under the top lid of the cold box.

Figure 24: Vaccine carrier



3.2.2 Vaccine Carriers

Vaccine carriers are used for carrying small quantities of vaccines (16-20 vials) to the sub-centers or session sites. The vaccine carriers are made of insulated material, the quality of which determines the cold life of the carrier. Four ice packs are laid in the vaccine carrier as per manufacturer's guidelines. Conditioned icepacks should only be placed and the lid of the carrier should be closed tightly.

The vials of DPT, DT TT and Hep B vaccines should not be placed in direct contact with the frozen ice packs.

Uses

To carry vaccine from PHC to outreach sessions.

How to pack a vaccine carrier

- Confirm that there are no cracks in the walls of the vaccine carrier.
- Take out the required number of ice packs from the deep freezer and wipe them dry. Keep them out side for conditioning before placing into carrier.
- Place four numbers conditioned ice packs in the carrier and wait for few minutes for temperature to fall to less than 8 degree Celsius in the carrier.
- Wrap vaccine vials and ampoules in thick paper (say newspaper) before putting in polythene bag so as to prevent them from touching the ice packs. Place some packing material between `T` series vaccine and the ice packs to prevent them from touching the ice packs.
- Place foam pad at the top of ice packs.
- Ensure that some ice is present in the ice packs while conducting immunization sessions.
- Secure the lid tightly.

1 Prepare Ice-Packs for Freezing

- Fill the Ice-Pack with water to mark. Check water level before every use. Do NOT add salt to this water.
- Fit the stopper and screw on the cap tightly.
- Make sure the Ice-Pack does not leak.
- Wipe the Ice-Pack dry and place in the Deep Freezer.

2 Condition Frozen Ice-Packs

- Place frozen Ice-Packs in the open till they "sweat," (some condensation or droplets of water).
- Check if an Ice-Pack has been conditioned by shaking it and listening for water.

Unconditioned Ice-packs may damage freeze sensitive vaccines (DPT, DT, TT and Hepatitis B).

3 Pack the Vaccine Carrier

- Place four conditioned Ice-Packs against the sides of the carrier.
- Place the plastic bag containing all vaccines and diluents in the centre of the carrier.

4 Remember to..

- Collect vaccines in the carrier on the session day (Vaccine carriers may not store vaccines effectively beyond 12 hrs).
- Do not drop or sit on the vaccine carrier.
- Do not leave in sunlight. Keep in shade.
- Do not leave the lid open once packed.

If more than one vaccine carrier is being carried, keep the whole range of the vaccines required for the day's use in each carrier so that only one carrier is opened at a time.

- Keep the vaccine carrier in good condition when not in use.
- Do not keep any load or sit on the carrier.
- Do not use any sharp tool to open the lid of the carrier.
- Clean and dry the inside after every use.
- **Never use day carrier containing two ice packs.**
- Avoid direct sun light and knocking.

Figure 25: Ice pack

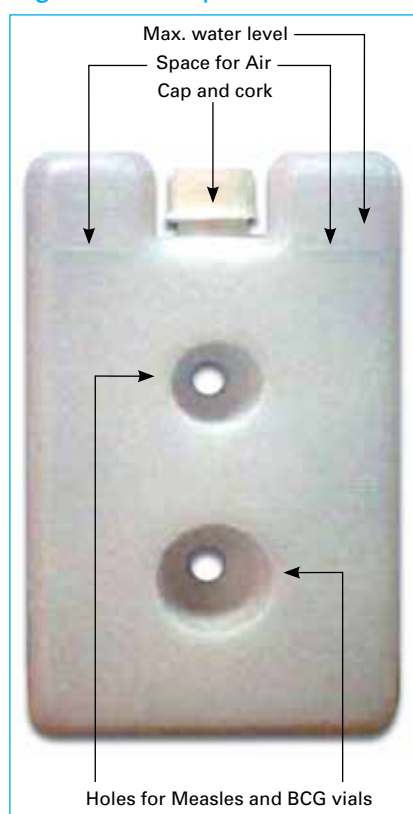

3.2.3 Ice Packs and their use

Ice packs are key component of the cold chain. It is used for ice lining inside the cold box and vaccine carrier. The ice packs are frozen inside the deep freezer under the temperature range of (-) 15 to (-) 25°C. The specifications of ice packs vary with the manufacturers.

The ice packs for cold box are different from vaccine carrier and these should be used as per the manufacturer's guidelines.

3.2.3.1 Preparation of ice packs

About 20-25 ice packs (8-10 Kg. Ice) and 35-40 ice packs (12-14 Kg. Ice) can be frozen in one day in small and large deep freezers respectively. You must make your plans in advance and start freezing ice packs several days before you need them, depending on your requirements. You may sometimes need a large number of ice packs such as in a pulse polio campaign or a mop up round. In such a situation, if an ice factory is located nearby, you may arrange to get the required number of frozen ice packs.

Ice packs are used to line the sides of cold boxes and vaccine carriers. Ice packs contain water. The water should be filled only up to the level mark on the side. Cork should be tight so that there is no leakage. If there is any leakage, such ice packs should be discarded. Clean the outer surface of ice packs with dry cloth before putting into the deep freezer. Ice packs should be stacked on the floor of the deep freezer horizontally (Not flat) on its edge by keeping 1-2 mm space from each other for air circulation, in a criss cross manner

(see figure given below). **Salt should never be added to the water**, as it lowers the temperature to sub-zero level, which is not recommended for DPT, DT, TT, Hep B and BCG vaccine. Once the ice packs are fully frozen, fresh set of ice packs can be prepared. For emergency requirements a PHC should have at least 60 frozen ice packs at any given time.

Planning for icepack freezing

1. For routine immunization

- a. Calculate the requirement of the ice packs for immunization day. Check your micro-plan and identify the maximum numbers of sessions in a week and numbers of vaccine carriers required in that week.
- b. Add 50 ice packs for preparation of cold box at the time of emergency. It will be your total requirement.
- c. The capacity of storing one small deep freezer is 130 ice packs if stacked as per the guidelines.
- d. Start freezing five day before the immunization day.
- e. Stack 20-25 (depending upon the ambient temperature) unfrozen ice packs and allow freezing for 24 hrs in the large compartment of DF.

Figure 26: Ice pack stacking in deep freezer

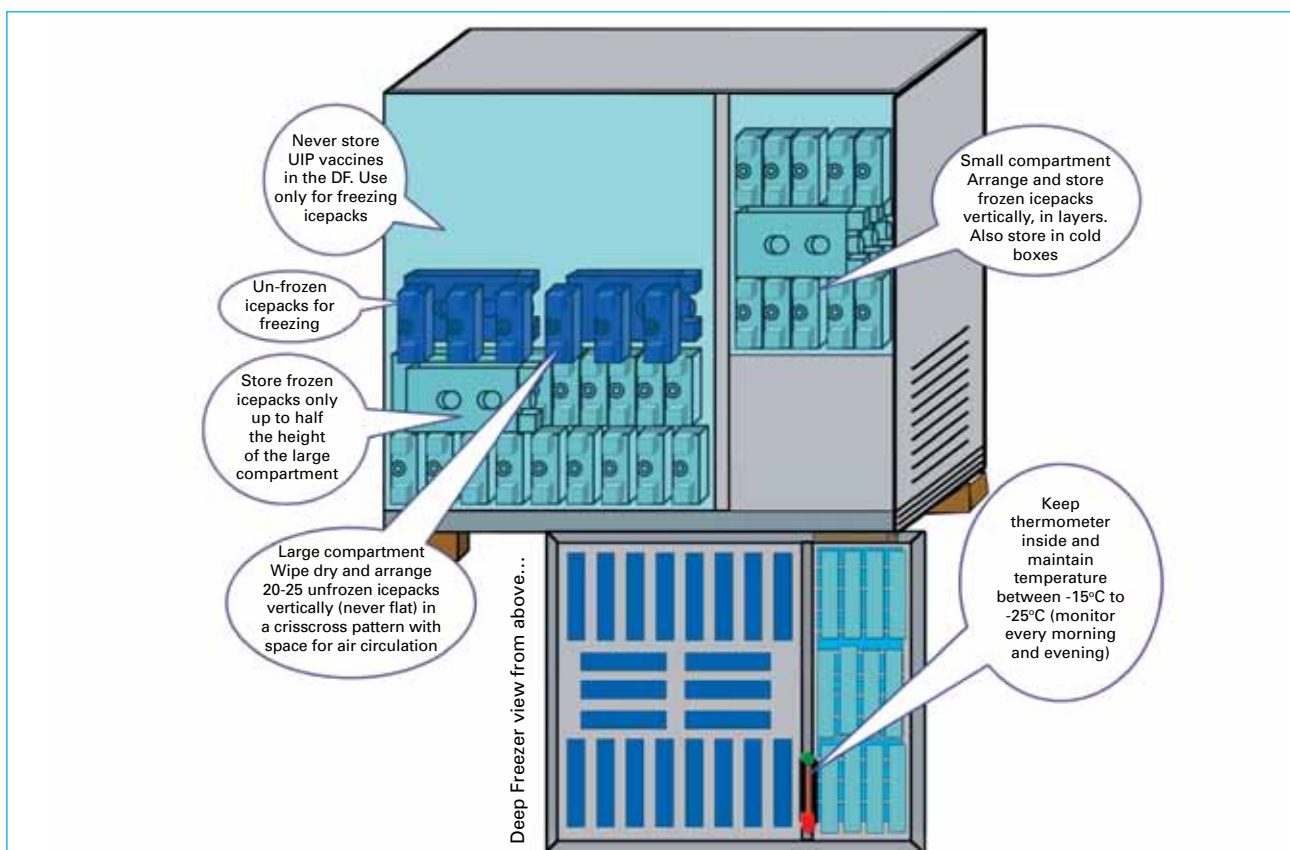

- f. The next batch of 20-25 unfrozen packs are to be kept on the top of the frozen ice packs as shown in the picture.
- g. The frozen ice packs should be stored only up to half the height of the large compartment. The small compartment in the DF can also be used to store ice packs.
- h. Continue the procedure till you get required numbers of ice packs.

2. For campaigns (Pulse polio/Measles/JE)

- a. Calculate the requirement as per teams to be deputed for campaign.
- b. Calculate the number of days required for getting frozen ice packs by dividing 20-25 ice packs in the requirement.
- c. Start freezing ice packs before the numbers of days required.
- d. After 100 ice packs transfer the frozen ice packs in to large cold box. One large cold box will accommodate 50 ice packs.
- e. 50 more ice packs can be frozen in two days.
- f. Continue the procedure till you get required numbers of ice packs.

3. Plan of issue of ice packs during pulse polio campaign

- a. During the pulse polio campaign you will have ice packs in deep freezer and cold boxes. The plan of issue of ice packs to the team is as under:
 - i. On the booth day, issue ice packs from deep freezer in the morning.
 - ii. Now you will get space in the deep freezer. Transfer the frozen ice packs kept earlier in cold boxes in the space you get in the deep freezer, so that they are hard frozen by next morning.
 - iii. In the evening, the returned ice packs from the field are to be kept in the cold boxes, since these ice packs will be approximately at 0°C.
 - iv. Next day morning ice packs will be issued from the deep freezer and the stored ice packs in cold boxes will again be transferred to the deep freezer for freezing.
 - v. The same procedure will be used till the end of the campaign.

Remember

- Do not use ice packs which are cracked and are without cap or cork. Check for any leakage before putting in the deep freezer.
- Ice packs should be filled up to the maximum level (marked on the top of the ice pack). While filling, ice pack should be kept vertically upwards under the tap so that it will overflow after reaching the desired level.
- Clean the outer surface of the ice packs with dry cloth.
- Keep only 20 to 25 ice packs in small deep freezer and 35 to 40 in large deep freezers depending upon the ambient temperature from 45 to 32°C at a time. Keep another set of same number of ice packs after getting frozen of previous set.
- Ice-packs need not be refilled every time they are used. The same water can be used repeatedly.

Figure 27: Ice packs conditioning

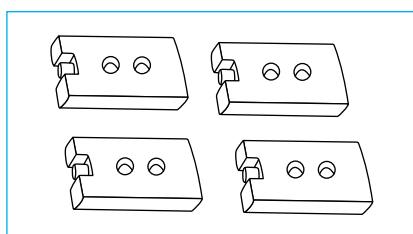

Figure 28: Conditioned ice pack



An ice pack is correctly conditioned when the water covers its surface and the sound of water is heard on shaking it.

3.2.3.2 Conditioning of ice packs

- Icepacks come out of the freezer at -15°C to -25°C.
- If placed immediately inside carrier, freeze-sensitive vaccines may freeze accidentally.
- Keep at room temperature for a period of time to allow temperature at core of icepack to rise to 0°C (conditioning).
- At start of session day, take all the frozen ice-packs you need from the freezer and close the door. Lay out on a table leaving a 5 cm space all round each icepack.
- Lay out icepacks, preferably in single rows but never in more than two rows.
- Check to see if ice inside the icepacks has begun to melt and some condensation, or droplets of water appears and listen for sound of water.

Chapter 4

Temperature Monitoring

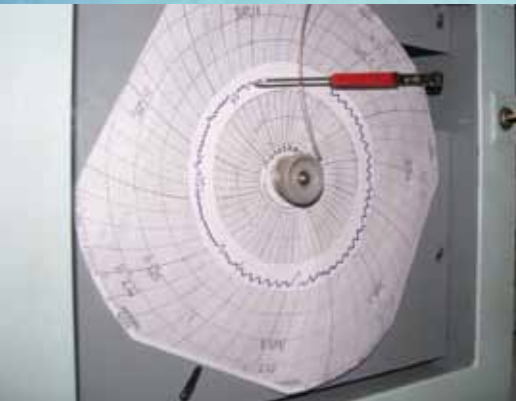

4

4.1 Storage Temperatures

4.2 Measuring and Recording of Temperatures

4.3 Recording & Monitoring of Storage Temperature

4.1 Storage Temperatures

Temperature of ILRs/Freezers used for storage of vaccines must be recorded twice daily. These records should be checked during supervisory visits. A break in the cold chain is indicated if temperature rises above +8°C or falls below +2°C in the ILR; and above -15°C in the Deep Freezer.

The ILR and Deep freezers each should have separate thermometer and temperature record book.

The serial numbers of ILR and deep freezers should be indicated at the top of the temperature record book and should be available near the equipment and every supervisory visit should be documented in the record.

Remember

- Keep one thermometer in every unit.
- Designate a staff member to record the temperature twice a day.
- Keep the booklet of 12 monthly temperature recording forms on the top of each unit and check daily to see that the temperature record is maintained.

Figure 29: Dial thermometer

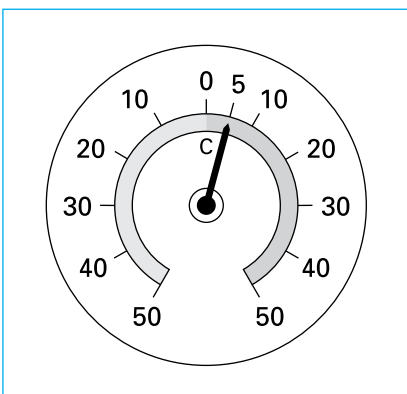

4.2 Measuring and Recording of Temperatures

To measure the temperature during storage/transport different type of thermometers and instruments are used.

4.2.1 Dial Thermometers

Dial thermometers have been provided to record the temperature in the ILRs/Freezers. It has dial with moving needle to show the temperature of vaccine with in the range of -50°C to +50°C.

Figure 30: Stem thermometer

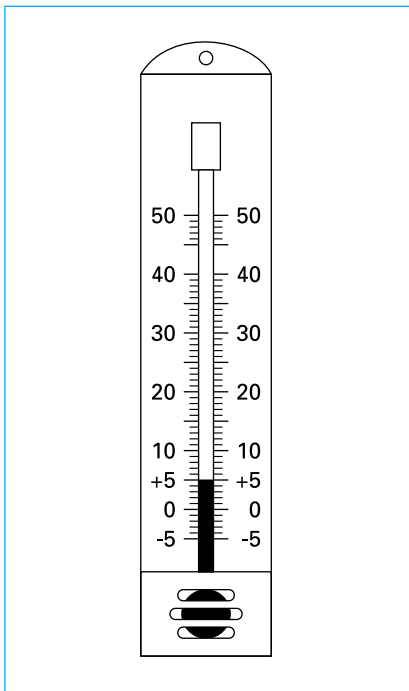

Figure 31: Electronic data logger



4.2.2 Alcohol Stem Thermometers

Alcoholic thermometers are much sensitive and accurate than dial thermometers. They can record temperatures from -50°C to $+50^{\circ}\text{C}$ and can be used for ILRs and deep freezers.

4.2.3 Electronic Data Logger

The electronic data loggers are also being introduced to monitor the temperature of ILR. It is an electronic device placed with the vaccine which records the vaccine temperature for 30 days. It has an alarm system and as soon as the temperature of the equipment storing the vaccine crosses the safe range alarm alerts the handlers. This device assists in temperature monitoring through following features:

1. It shows temperature of ILR in digital LCD screen at all the time
2. It indicates if there was any alarming situation during the past 30 days. The device shows "Alarm" on LCD screen if there was any alarming situation in past 30 days. The alarming situation is when the temperature went above $+8$ Degree Celsius over a consecutive period of ten hours or temperature drops down below -0.5 Degree Celsius for a consecutive period of 60 minutes.
3. It shows the duration of temperature violation for every alarming situation happened in past 30 days. To see the duration of temperature violation, device is equipped with an "Read" button which guides the user through the history of past 30 days starting from "today" till "30 days ago".
4. It shows an "OK" sign if there has been no violation of temperature in past 30 days.
5. It has a shelf life of two years from the date of activation of device. The device once activated, cannot be stopped through-out its operational life. Hence, it provides round the clock monitoring of ILRs without any need of intervention of user for two years of time.
6. It has been specifically designed to be used with ILRs and Walk-in-Coolers that are required to maintain the temperature between $+2$ to $+8$ Degree Celsius.

4.2.4 Freeze Indicator

It is also an electronic device to monitor vaccines exposed to less than 0°C . It contains an electronic temperature measuring circuit with associated LCD

Figure 32: Freeze indicator



display. If the indicator is exposed to a temperature below -0.5°C for more than 60 minutes the display will change from "good" status in to the "alarm" status .

The fridge indicator is placed in between freeze sensitive vaccines (Hepatitis B, DPT, TT, DT etc.)

Once it changes the cross, it can not be re-used or reset and will be discarded. **The vaccines should never be used without shake test when freeze tag shows the cross mark.** Its shelf life is five years.

4.3 Recording & Monitoring of Storage Temperature

The temperatures in the ILR & DF, must be monitored TWICE DAILY (morning and evening). The thermometer should be kept in between the freeze sensitive vaccine inside the basket of the ILR. As it is an alcoholic stem thermometer, it is very sensitive therefore **while taking reading of the thermometer it should not be taken out from the ILR.**

After recording the temperature, cold chain handlers should sign on the temperature record book. Every week Medical Officer in-charge should record the temperature and sign on the record book.

Remember

- Vaccines are damaged by heat whether they are exposed to a lot of heat in a short time (e.g., as a result of keeping vaccine in a closed vehicle in the sun) or a small amount of heat over a long period (e.g., as a result of the frequent opening of a refrigerator door).
- Maintaining the cold chain demands constant vigilance.

The recording of the temperature is done in order to:

- Record that vaccines were not exposed to temperatures above $+8^{\circ}\text{C}$ and below $+2^{\circ}\text{C}$.
- Check that the equipment is working properly.

You must be careful and ensure that the temperature in the ILR does not rise above $+8^{\circ}\text{C}$. Also you must check that the temperature does not fall below $+2^{\circ}\text{C}$ as it damages the T series of vaccines. Adjust the thermostat switch in different seasons to maintain the inside temperature of the equipment well within the prescribed range. Do the shake test for T-series vaccines if temperature falls below 2°C .

The temperature records should be used to take action to shift vaccines to Cold Boxes or other ILRs when temperature warrants.

Figure 33: Temperature record book

Month Year

Date	Temperature (°C)		Power Failure (in hours)	Remarks (if any)
	10 AM	4 PM		
1.				
2.				
3.				
4.				
5.				
6.				
7.				
8.				
9.				
10.				
11.				
12.				
13.				
14.				
15.				
16.				
17.				
18.				
19.				
20.				
21.				
22.				
23.				
24.				
25.				
26.				
27.				
28.				
29.				
30.				
31.				

Note:-
 1. MO/IC should check and sign weekly
 2. Defrost if ice accumulation is more than 6mm. Enter the dates of defrosting in remarks column

5

Insulated Vaccine Van

It is an insulated mobile van used for the transportation of the vaccine by road in bulk quantity. The vaccines should only be transported through vaccine van only. Approximately 6 lakh to 10 lakh mixed antigen can be transported at a time. All vaccines should only be transported in cold boxes with desired number of frozen/conditioned ice packs or with dry ice.

- The loading of the cold boxes should be done at the coldest place available.
- Loading should be in minimum possible time.
- Close the rear door of the vaccine van immediately after the loading.
- Start for destination immediately.
- Same precaution may be taken during unloading.
- Shift the vaccine in the cold chain equipments immediately after reaching the destination point.

Figure 34: Insulated vaccine van



Chapter 6

Maintenance of Cold Chain Equipments



6

6.1 Cold Chain Maintenance System

6.2 Terminologies related to Cold Chain Maintenance System

6.3 Float Assembly (Similar to a Spare Wheel)

6.4 Manpower Deployment

6.5 Preventive Maintenance of ILR/Deep Freezer

6.6 Trouble Shooting

6.7 How to Avoid Vaccines from Freezing

6.8 Shake Test

6.9 How to Maintain a Vaccine Carrier/Cold Box

6.1 Cold Chain Maintenance System

The challenge for sustaining immunization activities lies in maintaining equipment at various levels. Under the immunization program, it is intended to have minimal equipment out of order at any point of time, all repairs responded to and attended within 7 days in case they are minor, and within 21 days in case of major repairs.

As cold chain handlers, who will be responsible for day to day component of preventive maintenance of PHC/district, and also for the mechanic, who will be responsible for undertaking minor/major repairs, it is very essential for you to know:

- The details related to breakdown of equipment.
- Categorization of repairs as major and minor.
- Concept of float assembly/spare units to be redeployed to replace defective units.
- Spare parts should be available at various levels.

In the next few pages, you will be learning about some of these details. Please take some time to discuss these issues with your Cold Chain Officer/Mechanic/Health worker responsible for maintaining equipment in your district/PHC.

6.2 Terminologies related to Cold Chain Maintenance System

Following are certain terminologies you should be familiar with:

6.2.1 Cold Chain Sickness Rate

This is the proportion of cold chain equipment out of order at any point of time e.g. if there are 100 ILRs/Freezers in a district and 7 are out of order (equipment

declared condemned should not be counted), the cold chain sickness rate on that day is 7 percent.

6.2.2 Response Time

The time required to get the defect attended to from the time of sending information to actually attending it is called response time (e.g. if an ILR is out of order on 10th April and a message is sent for the mechanic on 10th of April, and a refrigerator mechanic attends to it on 12th April to check the fault, the response time is 2 days).

6.2.3 Down Time

For a cold chain equipment down time means the period the equipment remains out of service (e.g. if an ILR is out of order on 10th April, and is functional again on 20th April, the down time is 10 days. Similarly, if an ILR is out of order on 10th April and is functional on 13th April, the down time is 3 days).

6.2.4 Sickness Reporting

Efficient reporting system contributes greatly to reduce the “down time” of the equipment. It is desirable for efficient maintenance that the reporting should be direct from “who wants the service” to “who will provide the service” (with intimation to the other officers concerned).

The most reliable means of communication (telephone, special messenger post, telegraph, etc. in the concerned area), whichever is the fastest, should be used. **The aim is to maintain a response time of 2 days.**

Design your own reporting system which is “direct user to service centre”.

You should establish a sound maintenance system in your district. You have to monitor its effectiveness. A good maintenance system must ensure that:

- At any point of time, not more than 2% of the cold chain equipment (ILR/Freezer) remains out of order; and all WICs are functional.
- Break-down is reported and attended to immediately, and minor repairs carried out maximum within 7 days and major repairs

maximum within 3 weeks of break down by the district mechanic.

- Maximum 4-6 hours be allowed for repairing electrical faults of WICs.

6.3 Float Assembly (Similar to a Spare Wheel)

Norms of float assembly at district HQ:		
1.	ILR	5% of total ILRs available in the district.
2.	Freezers	5% of total Freezers available in the district.
3.	Voltage stabilizer-1 KVA	20% at District HQ

A float assembly is a stock of spare units of cold chain equipment (at district/state headquarters) for immediate replacement of defective units (brought from the Primary Health Centers). The defective units once repaired go into the float assembly.

Float assemblies are required for the effective maintenance of the cold chain so that no time is lost while the machine is out of order. District mechanics should therefore have voltage stabilizers, which they can replace at the site and bring the defective instruments back to the workshop. At district level, 20% spare voltage stabilizers should be available as a float assembly to ensure timely replacement.

6.4 Manpower Deployment

Time consuming procedural formalities should be shortened. The person In-charge of the regional/district level should issue the deployment/movement orders to the technicians to attend the repair jobs immediately after receipt of the complaints. In some cases when he cannot be empowered for the same, the procedures for obtaining concurrence from the higher required level should be shortened as much as possible.

Every month, information has to be collected on the number of units functioning as well as on how soon repair was completed. You must take immediate action based on this information. In order to have an effective maintenance system, the following must be ensured:

- Adequate quantity of spare parts for minor repairs should be available with the refrigerator mechanic.
List of spare parts for minor repairs are as under:

List of fast moving spares/tools at PHC level:

1. Starting device/relay
2. Thermostat

3. Starting capacitor
4. 15 A – 3 pin plug and socket – ISI marked
5. 7/20 single core copper conductor (wire)
6. Insulation tape
7. Screw driver set
8. Phase tester
9. Test lamp

- Repairs are categorized as major and minor. The district technician can undertake minor repairs on site, and must be fully equipped to do so. All major repairs will have to be undertaken at a workshop. The maximum time allowed for reinstallation of ILR/Freezer after a major repair including transportation to and fro is 3 weeks.
- The district mechanic should have some contingency funds available with him for minor repairs.

6.5 Preventive Maintenance of ILR/Deep Freezer

It is a responsibility of the district immunization officer that equipment and machinery in the district run to their optimum. This requires their preventive maintenance. It should be ensured that the refrigerator mechanic of the district or the district does preventive maintenance. A checklist for preventive maintenance is given below.

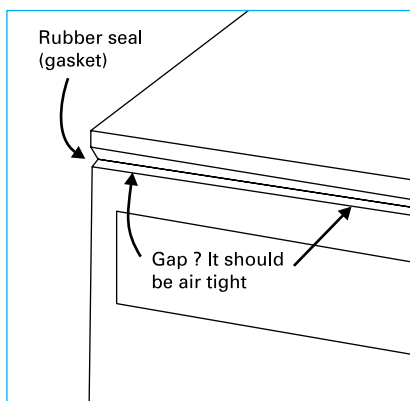

A log book to record the maintenance and repairs undertaken should be maintained at the cold chain depot.

Daily checkup

1. Out side equipment neat and clean
2. Equipment in level
3. Recording temperature twice daily
4. Checking of Seal and door

Weekly checkup

1. Signature by MOIC
2. Check rubber seal (Gasket) of the lid. It should be fit tight
3. Monitor temperature
4. Defrost if necessary

Monthly checkup

1. Defrost the equipment
2. Adjust thermostat if necessary

6.5.1 Defrosting and Cleaning

The temperature in the ILR/Freezer can rise if there is a thick layer of ice around the freezer or along the walls and bottom of ILRs. It is therefore necessary to defrost them periodically. This should be done if the ice in the freezer is > 5 mm thick.

As a cold chain handler you have to ensure that the Deep Freezers/ILRs are regularly defrosted and cleaned. The following points should be observed:

- Vaccines need to be transferred to the Cold Box (or another ILR) for temporary storage. In case of Freezer, take the frozen ice packs out and keep them in a cold box or close together with adequate no. of conditioned ice packs.
- Power supply needs to be switched off and the plug removed from the wall socket.
- Keep the lid open and allow the frost to melt completely. Never use any heat source other than warm water to speed up defrosting. Never use any sharp-edged instrument for removing frost or for cleaning.
- Open the defrost water outlet plug at the bottom of the cabinet.
- Wash all parts inside the cabinet with warm water and mild detergent, wipe it dry with clean cloth. Never use any strong detergent or rubber reactive material for cleaning the rubber seal.
- Allow the cleaned parts to dry completely. Reset the drain outlet plug at its position at the bottom and close it with the plug.
- Close the lid. Connect the power supply plug to the wall socket.
- Turn the thermostat knob to right (clockwise) to maximum position. Observe the temperature and wait till the temperature reaches within the range.
- Turn the thermostat to normal (N) position. Observe the temperature for another 4-6 hours. See the temperature is within the range (reset thermostat if temperature comes out of safe range).
- Load the vaccine/ice packs.

6.5.2 Dos and Don'ts for Use of ILR/Freezer

Dos

- Keep the equipment in a cool room away from direct sunlight and at least 10 cms away from the wall.
- Keep the equipment properly leveled.
- Fix the plug permanently to the socket.
- Use voltage stabilizer.
- Keep the vaccines neatly stacked with space between the stacks for circulation of air.
- Keep the equipment locked and open it only when necessary.
- Defrost periodically.
- Check the temperature twice a day and maintain a record, which should be supervised and signed by the concerned supervisor/Medical Officer regularly.
- Take remedial action if the temperature is not maintained within the prescribed limit.
- Outside the equipment paste a notice of the contingency plan that helps the user during a break down.
- Should know whom to contact and where to check for a blown fuse.
- Should arrange for alternate place for storing vaccines.

Don'ts

- Do not keep other drugs and vaccines not used in UIP.
- Do not open the top un-necessarily
(Paste this message on the top of the ILR).
- Do not keep food or drinking water in the DFs/ILR.
- Do not keep more than one month's requirement at PHC headquarters and 3 months requirement at district level.
- Do not keep vaccines, which have expired and which has crossed the discard point of VVM.
- Do not sit on any cold chain equipment.
- Do not disturb thermostat setting frequently.

6.6 Trouble Shooting

When the inside temperature of an equipment rises above 8°C, it requires to be checked immediately.

1. Green light or yellow switch is glowing

Check the equipment as given below:

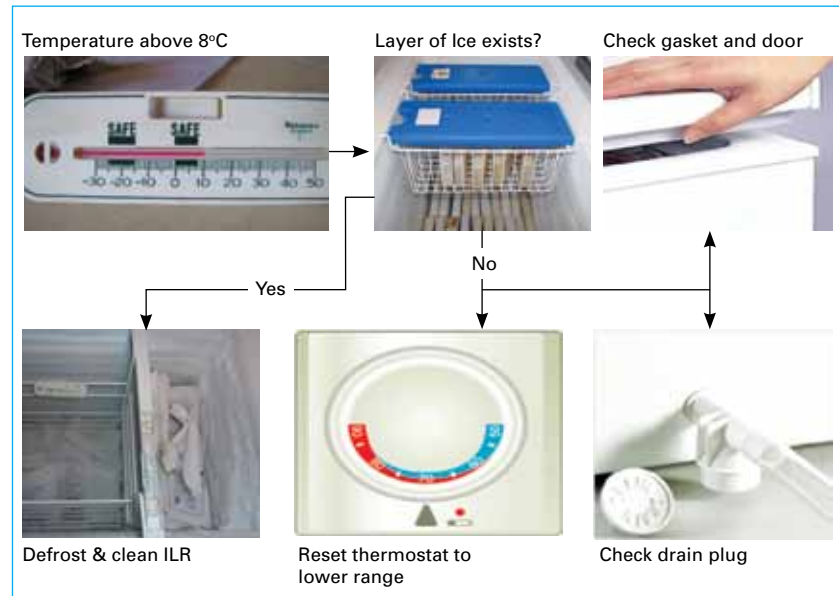

2. Green light or yellow switch is not glowing.

- Check power available up the socket. Use test lamp only. Test lamp will glow when phase and neutral connectivity is available. Electric tester may give false result.
- Check plug and socket connections.
- Check voltage stabilizer is in function.
- Cut off power supply and check the voltage stabilizer connections.

Ensure that power supply is available in proper voltage and neutral and earth connection is intact up to the switchboard, if not call the electrician.

6.7 How to Avoid Vaccines from Freezing

1. Causes of freezing

- Poor storage in Ice lined refrigerator
- Cold climates and ambient temperature is less than 0°C
- Transport with frozen ice packs
- Belief that the colder is better



- e. Low awareness and understanding
- f. Incorrect thermostat adjustment

2. Steps for eliminating freezing

- a. Keep all freeze sensitive vaccines in the basket of the ILR with Hep. B and DPT at top.
- b. Switch off Ice lined bypass switch.
- c. Load freeze-sensitive vaccines at least 5 cm away from evaporator.
- d. Defrost if ice lining exist (In ILR there should not be any ice lining, in Deep freezer it can be up to 5mm thick).
- e. Transport vaccines only with conditioned ice packs.
- f. It is believed that colder is better for any vaccine. Awareness should be created with different IEC posters.
- g. Proper training to all health workers and supervisors is required at every level.
- h. Thermostat of the ILR should be set at normal position. Average temperature setting of the ILR should be at 5°C.
- i. Thermostat should be set when the ambient temperature is lowest with in 24 hrs of the day.
- j. Never set the thermostat when power is cut off.
- k. Never adjust the thermostat when the temperature rises occasionally.
- l. Tap the thermostat after setting the average temperature at 5°C for 72 hrs and do not disturb frequently.
- m. Place the thermometer with the most freeze sensitive vaccines and check it twice a day.
- n. Leave space for air circulation.
- o. Conduct shake test in case of any doubt.

What to do if freezing occurs?

- Report evidence of freezing to supervisors for corrective action.
- If a freeze-sensitive vaccine is frozen solid, discard it immediately.
- If an indicator signals that freezing has occurred, immediately conduct the shake test on a sample of all affected vials.

3. Eliminating freezing in cold climates

- a. Keep cold rooms and vaccine refrigerators in heated rooms.
- b. Use room-temperature water packs for vaccine transport. Fill ordinary ice-packs with tap water; do not freeze or chill them. In extremely cold conditions, use ice packs filled with warm water at 20°C.
- c. Use freeze indicators in all refrigerators and cold boxes.
- d. Use a heated vehicle. Never leave cold boxes in an unheated vehicle, especially overnight.
- e. Do not leave cold boxes outdoors or in unheated rooms.

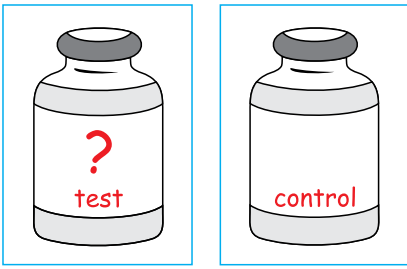

Use

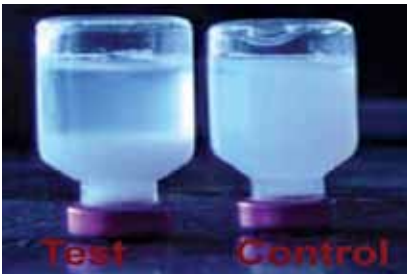

Discard

6.8 Shake Test

- Take a vaccine vial you suspect may have been frozen – This is “test” sample.
- Take a vaccine vial of the
 - same type, same manufacturer, same batch number as the suspect vaccine vial you want to test.
- Freeze solid this vial at (-) 20°C overnight, and this is the ‘CONTROL’ sample and label as FROZEN to avoid its usage.
- Let it thaw. Do NOT heat it.
- Hold the Control and the Test sample together in hand and vigorously shake the samples.
- Place both vials to rest on a flat surface, side-by-side observe them for 30 minutes.
- Compare for rate of sedimentation.
- If the sedimentation in the ‘Test vial’ is slower than in the “Frozen vial”: The vaccine has not been damaged.
- **Use.** The vaccine batch – it is not damaged.
- If the sedimentation is similar in both vials or if sedimentation is faster in the “Test” vial than in the “Frozen” vial: The vaccine is damaged.
- **Do NOT use.** Notify your supervisor.

6.9 How to Maintain a Vaccine Carrier/Cold Box

- Clean and dry after every use.
- Examine inside and outside surface for cracks.
- Check that the rubber seal around the lid is not broken.
- Adjust the tension on the latches (if provided) so that the lid closes tightly.
- Lubricate hinges and locks routinely.
- Never keep the lid in locked condition while not in use.
- Do not leave in sunlight: Keep in shade.
- Do not leave the lid open once packed.
- Never drop or sit on the vaccine carrier/cold box.

7

7.1 Vaccine Storage

7.2 Management of Vaccines and Logistics at State, District and PHC Levels

7.3 Distribution of Vaccines and Logistics

7.4 Distribution of Vaccines from PHC

7.5 Sub-Centre/Village/Session Level

7.6 Alternate Vaccine Delivery System (Avds)

7.7 Improving Vaccine use and Reducing Wastage

7.1 Vaccine Storage

Vaccines stored in cold chain at various levels at different temperatures for different periods. Different cold chain equipments are used for this purpose. See table 3 for details.

It is very essential to store proper stock of vaccines at every stage of cold chain. If it is in less quantity the immunization programme may suffer and in the case of excess quantity, there are chances of losing their potency. The quantity of the vaccines should be calculated for the period as mentioned in the table and a designated quantity should be added to keep as buffer stock.

While storing the vaccine, the following care should be taken:

- Keep the packets containing the vaccines in neat rows.
- Different vaccines should be kept separately to facilitate easy identification.
- Keep about, 2 cm. Space between rows for circulation of air. The carton of the boxes of vaccines should have holes to facilitate good access of cool air. Keep a separate thermometer among the vaccines to ascertain the actual vaccine temperature.
- Store DPT, TT, and Hep. B vaccines away from the inside walls or bottom of the ILR to avoid freezing. **Always keep the vaccines in the basket provided in the ILR.** Store OPV and measles vaccines at bottom of basket of the ILR.
- Diluents may not be stored in ILR (as it would occupy space which is not desirable), but keep diluents for at least 24 hrs before issue, in ILR. **At time of reconstitution it should be brought to the temperature of vaccines.**
- The period of time in which any vaccine remains

in cold chain stores without being used should be recorded.

- Same vaccines should be stored in same area.
- Diluents and freeze sensitive/early expiry date vaccines on top and heat sensitive/late expiry date vaccines on bottom.

7.2 Management of Vaccines and Logistics at State, District and PHC Levels

You will need to distribute vaccines and logistics (AD syringes, Hub cutters, Vitamin A, waste disposal bags, diluents, polyethylene bags etc.) to health centers in your region. A vaccine manager at the regional WIC store and district store must ensure that adequate stocks (including buffer stock) is available for catering to the monthly needs of all peripheral centers. You will receive vaccines from regional stores or state stores at regular intervals. Normally the supply will be for one to three months. This is because you will store vaccines for **no longer than three months in the district stores and one month in the PHC.**

Vaccines have a limited shelf life and lose their efficacy easily if not handled properly.

Table 3: Vaccine storage with duration at different level

Vaccine	At state level	At zonal level	At district level	At PHC/CHC level	During transportation
OPV	In WIF, (-) 15°C to (-) 25°C up to six months	In D/F (Large) (-) 15°C to (-) 25°C up to three months	In D/F (Large) (-) 15°C to (-) 25°C up to the three months	In ILR (small) (+) 2°C to (+) 8°C up to the one months	In cold boxes with hard frozen icepacks/dry ice.
Measles	In WIC, (+) 2°C to (+) 8°C up to six months	In WIC, (+) 2°C to (+) 8°C up to three months	In ILR (large) (+) 2°C to (+) 8°C up to the three months	In ILR (small) (+) 2°C to (+) 8°C up to the one months	In cold boxes with icepacks.
BCG	In WIC, (+) 2°C to (+) 8°C up to six months	In WIC, (+) 2°C to (+) 8°C up to three months	In ILR (large) (+) 2°C to (+) 8°C up to the three months	In ILR (small) (+) 2°C to (+) 8°C up to the one months	In cold boxes with icepacks.
DPT	In WIC, (+) 2°C to (+) 8 up to six months	In WIC, (+) 2°C to (+) 8°C up to three months	In ILR (large) (+) 2°C to (+) 8°C up to the three months	In ILR (small) (+) 2°C to (+) 8°C up to the one months	In cold boxes with conditioned icepacks.
TT	In WIC, (+) 2°C to (+) 8°C up to six months	In WIC, (+) 2°C to (+) 8°C up to three months	In ILR (large) (+) 2°C to (+) 8°C up to the three months	In ILR (small) (+) 2°C to (+) 8°C up to the one months	In cold boxes with conditioned icepacks.
Hep. B	In WIC, (+) 2°C to (+) 8 up to six months	In WIC, (+) 2°C to (+) 8°C up to three months	In ILR (large) (+) 2°C to (+) 8°C up to the three months	In ILR (small) (+) 2°C to (+) 8°C up to the one months	In cold boxes with conditioned icepacks.

Note: Vaccines can become unusable when VVM reaches discard stage. The unusable vaccines (due to any reason) should be kept out of cold chain.

You should ensure that you receive vaccines as per your requirement. **Do not allow large stocks to accumulate.** Check transport and storage arrangements. One person should be made responsible for receiving, storing and distributing vaccines. He should be properly trained for the task.

The batch of vaccines, which is going to expire first, should be utilized first if VVM is in usable stage. Please note – no vaccines should be utilized after expiry.

Keep 25% additional vaccines as buffer stocks for any unforeseen demand. The stocks must be rotated so that no vaccine is kept for more than one month in PHC.

Remember

- Do not keep vaccines for more than three months at the district stores and one month at PHC.
- Do not store any vaccines at sub-centers or outside cold chain.
- All vaccines are safe at temperatures between +2° to +8°C. Keep all vaccine in ice lined refrigerator in PHC.
- DPT, DT and TT and Hep-B vaccines should not be frozen. **DO NOT ALLOW THEM TO FREEZE**
- Transport vaccines in Cold Boxes or Vaccine Carriers only.
- Check ice packs before packing vaccines.
- While distributing vaccine select the shortest route.

You should know the amount of vaccine you have in storage and be sure that vaccine with earlier expiry date is used first. If two shipments of vaccines have the same expiry date, the one, which has remained longer in the store, should be used first.

Keep separate date-wise records of vaccine receipts, distribution and balance sheet for each type of vaccine and each size of vial. Note the expiry date of incoming batches and mark the arriving vaccine with arrival date (to provide a useful check on the age of the vaccine in the store). Keep record of vaccines distributed and estimated utilization at the centers. See figure 37 for performa of stock register.

Make a physical check of vaccine stocks during your supervisory visits. Make sure that records are properly maintained.

7.3 Distribution of Vaccines and Logistics

Your major responsibility is to provide vaccines to health centers in time.

Three major common issues in storage and distribution of vaccines and logistics are:

1. Stock out – A condition when no vaccine/logistics available.
2. Inadequate stock – Less than buffer stock i.e. 25% of vaccine and AD syringes.
3. Excess stock – More than requirement of one month and buffer stock i.e. more than 125% of vaccine and AD syringes.

Before making supplies, you must check the following

- Requirements of the PHC (session-wise).
- Utilization during the previous months. You can get this information from monthly monitoring report.
- Find out balance in hand.

Figure 35: Vaccine & logistics supply voucher

(Copy for Record for Supplier)				(Copy for Record for Receiver)			
Supply Voucher No.:	Date:	Received on:	Batch No.	Expiry date, VVM status	Remarks	Amount Released	Item
Reference Indent No	Dated:	Received on:	Batch No.	Expiry date, VVM status	Remarks	Amount Released	Item
To:				To:			
1	BCG (doses)						1 BCG (doses)
2	tOPV (doses)						2 tOPV (doses)
3	DPT (doses)						3 DPT (doses)
4	Hep B						4 Hep B
5	Measles (doses)						5 Measles (doses)
6	JE						6 JE
7	DT (doses)						7 DT (doses)
8	TT (doses)						8 TT (doses)
9	BCG Diluent (amp)						9 BCG Diluent (amp)
10	Measles Diluent (amp)						10 Measles Diluent (amp)
11	0.1ml AD Syringes						11 0.1ml AD Syringes
12	0.5 ml AD Syringes						12 0.5 ml AD Syringes
13	5 ml Disp. Syringes						13 5 ml Disp. Syringes
14	VitA Syrup						14 VitA Syrup
Received above vaccines and logistics in quantity mentioned and in good condition.				Received above vaccines and logistics in quantity mentioned and in good condition.			
Signature of Receiver:				Signature of Receiver:			
Name:				Name:			
Designation:				Designation:			

Figure 36: Vaccine and logistics indent form

(Copy for Record for Requester)			(Copy for Record for Receiver)				
Indent No.:	Date:		Indent No.:	Date:			
From:			From:				
To:			To:				
Item	Total amount received in current year	Balance available on date of indent	Amount requested	Item	Total amount received in current year	Balance available on date of indent	Amount requested
BCG (doses)				BCG (doses)			
tOPV (doses)				tOPV (doses)			
DPT (doses)				DPT (doses)			
Hep B				Hep B			
Measles (doses)				Measles (doses)			
JE				JE			
DT (doses)				DT (doses)			
TT (doses)				TT (doses)			
BCG Diluent (amp)				BCG Diluent (amp)			
Measles Diluent (amp)				Measles Diluent (amp)			
0.1ml AD Syringes				0.1ml AD Syringes			
0.5 ml AD Syringes				0.5 ml AD Syringes			
5 ml Disposable Syringes				5 ml Disp. Syringes			
VitA Syrup				VitA Syrup			
Signature of Receiver:	Signature of Requester:	Signature of Requester:	Signature of Receiver:	Signature of Requester:	Signature of Requester:	Signature of Receiver:	Signature of Requester:
Name:	Name:	Name:	Name:	Name:	Name:	Name:	Name:
Designation:	Designation:	Designation:	Designation:	Designation:	Designation:	Designation:	Designation:

Figure 37: Performa for stock register

(Note: all figures should be in doses, not in number of vials)

Name of Item: DPT		Storage Location: Garhi PHC						Year: 2008					
Date and Month	Opening Balance	Received			Issued			Loss/Adjustment Quantity	Returned Unused	End Balance	Remarks	Signature of IO/CC	
		From (Supplier)	Received Quantity	Batch No.	Expiry Date	VVM Status	Freeze Status*						To (Name of Facility)
1/2	100	District Stores	270	AG-100420	Dec 2009	usable	Liquid			370			
6/2									10	310			
13/2										230	Broken		
20/2									10	170			
27/2										100			
Total	100		270						10	280			

* Liquid or Frozen

7.3.1 Estimation of Requirements

Compile the micro plan of all sub-centers at the PHC level and estimate the requirement of vaccine and other supplies. Further more ensure that the overall estimate includes a buffer stock (25% for vaccine and syringes) and wastage 25% in the case of vaccines and 10% in the case of AD and disposable syringes at the:

- PHC level: for one month
- District level: for three month
- Divisional level: for three month

The buffer stock serves as a cushion as buffer against emergencies, major fluctuations in demand or unexpected transport delay.

How to calculate vaccine requirement for PHC:

To calculate vaccine monthly requirement of your PHC find out:

1. Annual target beneficiaries of your PHC.
2. Number of doses per child per antigen as per immunization schedule.

Calculate requirement for each antigen in vials as under:

$$\text{BCG} = \frac{\text{Yearly target infant} \times 1 \text{ dose} \times 1.25 \text{ (buffer)} \times 1.33 \text{ (wastage)}}{12 \times 10 \text{ (nos of doses per vial)}}$$

$$\text{DPT} = \frac{\text{Yearly target infant} \times 5 \text{ dose} \times 1.25 \text{ (buffer)} \times 1.33 \text{ (wastage)}}{12 \times 10 \text{ (nos of doses per vial)}}$$

$$\text{OPV} = \frac{\text{Yearly target infant} \times 4 \text{ dose} \times 1.25 \text{ (buffer)} \times 1.33 \text{ (wastage)}}{12 \times 20 \text{ (nos of doses per vial)}}$$

$$\text{Measles} = \frac{\text{Yearly target infant} \times 1 \text{ dose} \times 1.25 \text{ (buffer)} \times 1.33 \text{ (wastage)}}{12 \times 5 \text{ (nos of doses per vial)}}$$

$$\text{TT} = \frac{\text{Yearly target (PW)} \times 3.5 \text{ dose} \times 1.25 \text{ (buffer)} \times 1.33 \text{ (wastage)}}{12 \times 10 \text{ (nos of doses per vial)}}$$

$$\text{Hep. B} = \frac{\text{Yearly target infant} \times 4 \text{ dose} \times 1.25 \text{ (buffer)} \times 1.33 \text{ (wastage)}}{12 \times 10 \text{ (nos of doses per vial)}}$$

$$\text{JE} = \frac{\text{Yearly target (1-2 yr)} \times 1 \text{ dose} \times 1.25 \text{ (buffer)} \times 1.33 \text{ (wastage)}}{12 \times 5 \text{ (nos of doses per vial)}}$$

$$\text{MR} = \frac{\text{Yearly target (1-2 yr)} \times 1 \text{ dose} \times 1.25 \text{ (buffer)} \times 1.33 \text{ (wastage)}}{12 \times 5 \text{ (nos of doses per vial)}}$$

Vaccine vials requirement should be based on session wise microplan. All vaccine should be available in each session (minimum one vials).

Calculation of requirement of AD and disposable syringes

The requirement of AD syringes can be calculated:

1. On the required doses of the vaccine
2. Wastage factor 10%

Calculate syringes requirement:

0.1 ml AD syringes = Number of beneficiaries for BCG per month x 1.1 (wastage)

0.5 ml AD syringes = Number of beneficiaries per month (DPT + Measles + TT + Hep. B + JE) x 1.1 (wastage)

5 ml disposable = Required number of vials (BCG + Measles + JE*) x 1.1 (wastage)

* *when applicable*

7.3.2 Inventory Control System

The problem of stock out, inadequate or excess stock can be avoided if a minimum and maximum stock inventory control system is implemented. This system ensures that the quantity in hand is always between established maximum and minimum stock level.

Minimum stock level

This is also known the reorder level. It implies the least amount that should have in your stock or the level which, when reached, initiates a re-order; usually expressed as the numbers of weeks/months of supply. It is an amount of stock, which is used in the time between placing and receiving the order plus the buffer stock. The minimum stock level is the level below which stock should never drop without having placed an order.

Maximum stock level

It implies the large amount of stock that should have usually expressed in terms of numbers of weeks/ months of supply. It is the minimum stock plus the amount of stock used between orders. The maximum level is set to guard against the excess stock, which results in loosing vaccines to expiration before use.

Lead time

It is time between ordering of new stock and receipt/ available for use. The lead time varies, depending

upon the speed in deliveries, availability and reliability of transport, and some times the weather. For instances if DPT monthly requirement of a PHC is 280 doses, the buffer stock will be 25% of 280 i.e. 70 doses. If the lead time is one week than the minimum stock will be buffer stock plus requirement for lead time (70 doses) i.e $70+70=140$ doses.

The maximum stock level will be: the minimum stock + the stock required between the orders (for three week stock) i.e 210 doses. Therefore the maximum stock level will be $140+210=350$ doses.

If the stock falls below the re-order level inform the district vaccine store to replenishment and place an indent to avoid any shortage or stock out.

Systematically arrange the vaccines and supplies to facilitate issue of stock whose expiry date is closest, freeze sensitive vaccines at top and other vaccines at boom of the ILR.

During receipt, check and record the details of vaccines, diluents and other supplies, enter all details in the logistics and stock register immediately including batch number, expiry date, and status of VVM etc.

While in storage, periodically conduct physical verification of the stock at least once in a month. Check and record the details at the bottom of the stock register. Any expired vials, heat damaged or frozen vials, VVM at the discard point should not appear in the available stock balance and also should not be kept in the cold chain.

7.4 Distribution of Vaccines from PHC

Vaccines are delivered to the PHC from the district stores. It is best that vaccines are obtained at regular intervals. For example, vaccines may be delivered once a month or once every two weeks. However, vaccines are to be delivered at least once a month. This is because a PHC must not hold more than one month's stock.

No vaccine should be stored at the sub-centers. The vaccines are to be distributed to the session

sites on the day of session through alternate vaccine delivery mechanism so that vaccinator spend adequate time for immunization.

Ensure that all the vaccine and their respective diluents are kept in the vaccine carrier for distribution to session sites. Note **ONLY** the diluents supplied along with vaccine are to be used and no other diluents can be used even if they are chemically same.

Only one reconstitution syringe is to be used per vial, so supply the adequate number of 5 ml reconstitution (Diluents) syringe. Re-use of reconstitution (diluents) syringe for reconstituting more than one vaccine vial even if they are same vaccine may cause Adverse Event Following Immunization (AEFI). Supply adequate number of AD Syringe and other logistics taking wastage into account.

After the immunization session, vaccine that has been returned unused and unopened must be carried back to the PHC under cold chain on the same day and to be kept in ILR at the PHC (provided the VVM of the vial is in usable stage). These vaccines are to be used first on the next immunization day. To ensure that **RETURNED vaccine (unused and not opened) is selected first**, these vials should be placed in a box in the ILR marked "returned". One rubber band should be put for the first visit and two if the vial was taken out twice. If it is not used even during the third session, it should be brought to the PHC and discarded as per guidelines for immunization waste disposal as mentioned in the Immunisation Handbook for health workers 2006.

No opened vial should be stored as returned vial. Once the vial is opened it should be discarded after the end of the session or at the end of stipulated time after the reconstitution whichever occurs earlier.

MO (PHC) will be responsible for distributing vaccines for use in the sub-centers and also in the out reach sessions. Before sending vaccines, the following must be ensured:

- Actual requirements of the sub-centers.
- The ice packs of the vaccine carriers are conditioned.
- The temperatures of vaccines and diluents are same and of same manufacture.

Remember

- Keep a record of storage temperature; monitor and take action when warranted.
- First issue the vial which received from session sites as a returned vaccine. Never issue the vial received more than three times as returned vial.
- Usable vaccines with darker VVM should be issued first.
- Early To Expire First To Out (EEFO).
- Follow First-In-First Out Rule (FIFO).

- Sufficient quantity of diluents for the next day's use is kept in the ILR and taken to the field in Vaccine Carriers.
- The diluents are not frozen, as the ampoules are likely to crack when frozen.

The sub-centers should not be provided with the vaccine more than their requirement. Vaccines should be returned to the PHC on the same day. If it is not possible to return the vaccines on the same day, they can be sent on the next day only if the ice packs/ice has not fully melted. Opened vials of the vaccines should be sent to PHC for discarding and should not be reused for the next day.

On returning to the health centre

- **If ice packs in the carrier still contain ice:** Unopened vials should be marked by putting rubber band, and return them to the ILR/Freezer **BE SURE TO USE THESE MARKED VIALS DURING THE NEXT IMMUNIZATION SESSION.**

Same vial of the vaccine should not be taken out to the field more than **THREE TIMES**. If a vial of vaccine has been taken to the field third time, it should be returned to the PHC after marking 'Discard'. MO (PHC) must however, be careful that vaccines are not wasted in this way too often.

Opened vials should be kept in a plastic bag and returned to PHC at the end of the session. These are kept for testing in case of any adverse event. They are discarded after one week as per the guidelines for immunization waste disposal as mentioned in the Immunisation Handbook for health workers 2006.

- If the ice in the ice pack is completely melted: Examine the VVM status on the vial of OPV. **NEVER USE OPV WITH VVM AFTER DISCARD POINT (Discard it)**. If it is in usable stage, look for the date of expiry. If it has not passed, it can be used.

Mark the remaining DPT, Tetanus Toxoid, measles and BCG vaccine, return it to the ILR/Freezer and use it during the next session.

Update records on vaccine use:

- Keep a record of the vaccines you administer.
- Keep record of the batch numbers and expiry dates of the vaccines used.
- Keep record of vaccines returned to PHC.

When vaccine arrives at the PHC:

- Check that the types and amount of vaccine and diluents are the same as per your indent.
- Check the VVM and expiry date on each vial of vaccine.
- Transfer vaccines to the ILR/Freezer immediately after delivery to the health centre.

7.5 Sub-Centre/Village/Session Level

The risk of cold chain failure is greatest at sub-centre and village level. For this reason, the health worker is the most important link in the cold chain. **VACCINES ARE NOT STORED AT THE SUB-CENTRE LEVEL AND MUST BE SUPPLIED ON THE DAY OF USE.**

7.6 Alternate Vaccine Delivery System (AVDS)

As per alternate vaccine delivery system, vaccine and logistics should be delivered to the health workers at the immunization session sites so that she/he can start the immunization session on time, vaccine are collected on the same day and unused/opened vials and immunization waste are brought to PHC on the same days.

There are various ways of implementation AVDS like:

- Hiring of vehicle/ Autorickshaw
- Motor cycle/Bicycle
- Potter
- Boats etc.

Before issue of vaccine carrier to the AVD system porter following care should be taken:

- Only required quantities of vaccine and other logistics must be supplied.
- The vaccine carrier must have conditioned ice packs.
- A list of vaccines and logistics (including ADS syringe Hub cutter, Red and Blank bag etc.) for each immunization site must accompany with each session.
- At the time of supply VVM should not be beyond discard point.
- The vaccine carrier should be tight fit and should not be open during its transportation.
- Used and unused vials must be returned to the PHC the same day.

Figure 39: Alternate vaccine delivery plan year 2009-10

District: Banswara		Block : Garhi					Health Facility: Garhi PHC						
ILR Point: Garhi PHC		Day: Wed 1☑ 2☐ 3☐ 4☐ 5☐ 6☐ 7☐ 8☐ 9☐ 10☐ 11☐ 12☐ 13☐ 14☐ 15☐ 16☐ 17☐ 18☐ 19☐ 20☐ 21☐ 22☐ 23☐ 24☐ 25☐ 26☐ 27☐ 28☐ 29☐ 30☐ 31☐ 32☐ 33☐ 34☐ 35☐ 36☐ 37☐ 38☐ 39☐ 40☐ 41☐ 42☐ 43☐ 44☐ 45☐ 46☐ 47☐ 48☐ 49☐ 50☐ 51☐ 52☐ 53☐ 54☐ 55☐ 56☐ 57☐ 58☐ 59☐ 60☐ 61☐ 62☐ 63☐ 64☐ 65☐ 66☐ 67☐ 68☐ 69☐ 70☐ 71☐ 72☐ 73☐ 74☐ 75☐ 76☐ 77☐ 78☐ 79☐ 80☐ 81☐ 82☐ 83☐ 84☐ 85☐ 86☐ 87☐ 88☐ 89☐ 90☐ 91☐ 92☐ 93☐ 94☐ 95☐ 96☐ 97☐ 98☐ 99☐ 100☐ 101☐ 102☐ 103☐ 104☐ 105☐ 106☐ 107☐ 108☐ 109☐ 110☐ 111☐ 112☐ 113☐ 114☐ 115☐ 116☐ 117☐ 118☐ 119☐ 120☐ 121☐ 122☐ 123☐ 124☐ 125☐ 126☐ 127☐ 128☐ 129☐ 130☐ 131☐ 132☐ 133☐ 134☐ 135☐ 136☐ 137☐ 138☐ 139☐ 140☐ 141☐ 142☐ 143☐ 144☐ 145☐ 146☐ 147☐ 148☐ 149☐ 150☐ 151☐ 152☐ 153☐ 154☐ 155☐ 156☐ 157☐ 158☐ 159☐ 160☐ 161☐ 162☐ 163☐ 164☐ 165☐ 166☐ 167☐ 168☐ 169☐ 170☐ 171☐ 172☐ 173☐ 174☐ 175☐ 176☐ 177☐ 178☐ 179☐ 180☐ 181☐ 182☐ 183☐ 184☐ 185☐ 186☐ 187☐ 188☐ 189☐ 190☐ 191☐ 192☐ 193☐ 194☐ 195☐ 196☐ 197☐ 198☐ 199☐ 200☐ 201☐ 202☐ 203☐ 204☐ 205☐ 206☐ 207☐ 208☐ 209☐ 210☐ 211☐ 212☐ 213☐ 214☐ 215☐ 216☐ 217☐ 218☐ 219☐ 220☐ 221☐ 222☐ 223☐ 224☐ 225☐ 226☐ 227☐ 228☐ 229☐ 230☐ 231☐ 232☐ 233☐ 234☐ 235☐ 236☐ 237☐ 238☐ 239☐ 240☐ 241☐ 242☐ 243☐ 244☐ 245☐ 246☐ 247☐ 248☐ 249☐ 250☐ 251☐ 252☐ 253☐ 254☐ 255☐ 256☐ 257☐ 258☐ 259☐ 260☐ 261☐ 262☐ 263☐ 264☐ 265☐ 266☐ 267☐ 268☐ 269☐ 270☐ 271☐ 272☐ 273☐ 274☐ 275☐ 276☐ 277☐ 278☐ 279☐ 280☐ 281☐ 282☐ 283☐ 284☐ 285☐ 286☐ 287☐ 288☐ 289☐ 290☐ 291☐ 292☐ 293☐ 294☐ 295☐ 296☐ 297☐ 298☐ 299☐ 300☐ 301☐ 302☐ 303☐ 304☐ 305☐ 306☐ 307☐ 308☐ 309☐ 310☐ 311☐ 312☐ 313☐ 314☐ 315☐ 316☐ 317☐ 318☐ 319☐ 320☐ 321☐ 322☐ 323☐ 324☐ 325☐ 326☐ 327☐ 328☐ 329☐ 330☐ 331☐ 332☐ 333☐ 334☐ 335☐ 336☐ 337☐ 338☐ 339☐ 340☐ 341☐ 342☐ 343☐ 344☐ 345☐ 346☐ 347☐ 348☐ 349☐ 350☐ 351☐ 352☐ 353☐ 354☐ 355☐ 356☐ 357☐ 358☐ 359☐ 360☐ 361☐ 362☐ 363☐ 364☐ 365☐ 366☐ 367☐ 368☐ 369☐ 370☐ 371☐ 372☐ 373☐ 374☐ 375☐ 376☐ 377☐ 378☐ 379☐ 380☐ 381☐ 382☐ 383☐ 384☐ 385☐ 386☐ 387☐ 388☐ 389☐ 390☐ 391☐ 392☐ 393☐ 394☐ 395☐ 396☐ 397☐ 398☐ 399☐ 400☐ 401☐ 402☐ 403☐ 404☐ 405☐ 406☐ 407☐ 408☐ 409☐ 410☐ 411☐ 412☐ 413☐ 414☐ 415☐ 416☐ 417☐ 418☐ 419☐ 420☐ 421☐ 422☐ 423☐ 424☐ 425☐ 426☐ 427☐ 428☐ 429☐ 430☐ 431☐ 432☐ 433☐ 434☐ 435☐ 436☐ 437☐ 438☐ 439☐ 440☐ 441☐ 442☐ 443☐ 444☐ 445☐ 446☐ 447☐ 448☐ 449☐ 450☐ 451☐ 452☐ 453☐ 454☐ 455☐ 456☐ 457☐ 458☐ 459☐ 460☐ 461☐ 462☐ 463☐ 464☐ 465☐ 466☐ 467☐ 468☐ 469☐ 470☐ 471☐ 472☐ 473☐ 474☐ 475☐ 476☐ 477☐ 478☐ 479☐ 480☐ 481☐ 482☐ 483☐ 484☐ 485☐ 486☐ 487☐ 488☐ 489☐ 490☐ 491☐ 492☐ 493☐ 494☐ 495☐ 496☐ 497☐ 498☐ 499☐ 500☐ 501☐ 502☐ 503☐ 504☐ 505☐ 506☐ 507☐ 508☐ 509☐ 510☐ 511☐ 512☐ 513☐ 514☐ 515☐ 516☐ 517☐ 518☐ 519☐ 520☐ 521☐ 522☐ 523☐ 524☐ 525☐ 526☐ 527☐ 528☐ 529☐ 530☐ 531☐ 532☐ 533☐ 534☐ 535☐ 536☐ 537☐ 538☐ 539☐ 540☐ 541☐ 542☐ 543☐ 544☐ 545☐ 546☐ 547☐ 548☐ 549☐ 550☐ 551☐ 552☐ 553☐ 554☐ 555☐ 556☐ 557☐ 558☐ 559☐ 560☐ 561☐ 562☐ 563☐ 564☐ 565☐ 566☐ 567☐ 568☐ 569☐ 570☐ 571☐ 572☐ 573☐ 574☐ 575☐ 576☐ 577☐ 578☐ 579☐ 580☐ 581☐ 582☐ 583☐ 584☐ 585☐ 586☐ 587☐ 588☐ 589☐ 590☐ 591☐ 592☐ 593☐ 594☐ 595☐ 596☐ 597☐ 598☐ 599☐ 600☐ 601☐ 602☐ 603☐ 604☐ 605☐ 606☐ 607☐ 608☐ 609☐ 610☐ 611☐ 612☐ 613☐ 614☐ 615☐ 616☐ 617☐ 618☐ 619☐ 620☐ 621☐ 622☐ 623☐ 624☐ 625☐ 626☐ 627☐ 628☐ 629☐ 630☐ 631☐ 632☐ 633☐ 634☐ 635☐ 636☐ 637☐ 638☐ 639☐ 640☐ 641☐ 642☐ 643☐ 644☐ 645☐ 646☐ 647☐ 648☐ 649☐ 650☐ 651☐ 652☐ 653☐ 654☐ 655☐ 656☐ 657☐ 658☐ 659☐ 660☐ 661☐ 662☐ 663☐ 664☐ 665☐ 666☐ 667☐ 668☐ 669☐ 670☐ 671☐ 672☐ 673☐ 674☐ 675☐ 676☐ 677☐ 678☐ 679☐ 680☐ 681☐ 682☐ 683☐ 684☐ 685☐ 686☐ 687☐ 688☐ 689☐ 690☐ 691☐ 692☐ 693☐ 694☐ 695☐ 696☐ 697☐ 698☐ 699☐ 700☐ 701☐ 702☐ 703☐ 704☐ 705☐ 706☐ 707☐ 708☐ 709☐ 710☐ 711☐ 712☐ 713☐ 714☐ 715☐ 716☐ 717☐ 718☐ 719☐ 720☐ 721☐ 722☐ 723☐ 724☐ 725☐ 726☐ 727☐ 728☐ 729☐ 730☐ 731☐ 732☐ 733☐ 734☐ 735☐ 736☐ 737☐ 738☐ 739☐ 740☐ 741☐ 742☐ 743☐ 744☐ 745☐ 746☐ 747☐ 748☐ 749☐ 750☐ 751☐ 752☐ 753☐ 754☐ 755☐ 756☐ 757☐ 758☐ 759☐ 760☐ 761☐ 762☐ 763☐ 764☐ 765☐ 766☐ 767☐ 768☐ 769☐ 770☐ 771☐ 772☐ 773☐ 774☐ 775☐ 776☐ 777☐ 778☐ 779☐ 780☐ 781☐ 782☐ 783☐ 784☐ 785☐ 786☐ 787☐ 788☐ 789☐ 790☐ 791☐ 792☐ 793☐ 794☐ 795☐ 796☐ 797☐ 798☐ 799☐ 800☐ 801☐ 802☐ 803☐ 804☐ 805☐ 806☐ 807☐ 808☐ 809☐ 810☐ 811☐ 812☐ 813☐ 814☐ 815☐ 816☐ 817☐ 818☐ 819☐ 820☐ 821☐ 822☐ 823☐ 824☐ 825☐ 826☐ 827☐ 828☐ 829☐ 830☐ 831☐ 832☐ 833☐ 834☐ 835☐ 836☐ 837☐ 838☐ 839☐ 840☐ 841☐ 842☐ 843☐ 844☐ 845☐ 846☐ 847☐ 848☐ 849☐ 850☐ 851☐ 852☐ 853☐ 854☐ 855☐ 856☐ 857☐ 858☐ 859☐ 860☐ 861☐ 862☐ 863☐ 864☐ 865☐ 866☐ 867☐ 868☐ 869☐ 870☐ 871☐ 872☐ 873☐ 874☐ 875☐ 876☐ 877☐ 878☐ 879☐ 880☐ 881☐ 882☐ 883☐ 884☐ 885☐ 886☐ 887☐ 888☐ 889☐ 890☐ 891☐ 892☐ 893☐ 894☐ 895☐ 896☐ 897☐ 898☐ 899☐ 900☐ 901☐ 902☐ 903☐ 904☐ 905☐ 906☐ 907☐ 908☐ 909☐ 910☐ 911☐ 912☐ 913☐ 914☐ 915☐ 916☐ 917☐ 918☐ 919☐ 920☐ 921☐ 922☐ 923☐ 924☐ 925☐ 926☐ 927☐ 928☐ 929☐ 930☐ 931☐ 932☐ 933☐ 934☐ 935☐ 936☐ 937☐ 938☐ 939☐ 940☐ 941☐ 942☐ 943☐ 944☐ 945☐ 946☐ 947☐ 948☐ 949☐ 950☐ 951☐ 952☐ 953☐ 954☐ 955☐ 956☐ 957☐ 958☐ 959☐ 960☐ 961☐ 962☐ 963☐ 964☐ 965☐ 966☐ 967☐ 968☐ 969☐ 970☐ 971☐ 972☐ 973☐ 974☐ 975☐ 976☐ 977☐ 978☐ 979☐ 980☐ 981☐ 982☐ 983☐ 984☐ 985☐ 986☐ 987☐ 988☐ 989☐ 990☐ 991☐ 992☐ 993☐ 994☐ 995☐ 996☐ 997☐ 998☐ 999☐ 1000☐		Sat 1 (2 (3 (4 (5 (Total Sessions on the day: 13				
List Session Sites on the same route for the day in increasing distance from ILR Point.													
Route No	Sl. No.	Session Site	Name of ANM	Distance from ILR Point	App. Time from ILR Point	Time of Departure from ILR Point	Time when Vaccine Carrier along with immunization waste will be collected back	Time when Vaccine Carrier along with immunization waste will be collected back	Mode of Transport (Vehicle Number)	Name of Courier/ Driver			
Route 1: Garhi- Peepalkhunt- Pratapgarh Road	1	Chhari AWC	Sushma Pargi	3 km	6 mins	8.00 AM	3.51 PM	3.51 PM	Hired Jeep (RA01-2869)	Krishnalal Patidar			
	2	Bhagora SC	Rameela Chauhan	7 km	15 mins		3.37 PM	3.37 PM					
	3	Dunglawani AWC	Jamna Kumari	10 km	20 mins		3.27 PM	3.27 PM					
	4	Rohaniya h/o Sarpanch	Sharada Singh	12 km	25 mins		3.17 PM	3.17 PM					
	5	Sarwan AWC	Bhubneshwari	15 km	30 mins		3.07 PM	3.07 PM					
	6	Sodalpur Pry School	Gulab Devi Meena	16 km	32 mins		3.00 PM	3.00 PM					
Route 2: Garhi Kushalgarh Road	1	Kushalgarh SC	Geeta Rani	6 km	12 mins	8.00 AM	3.36 PM	3.36 PM	PHC Van (RAR-2686)	Nathu Ram			
	2	Sabalpura AWC	Gajendra Kumari	8 km	16 mins		3.25 PM	3.25 PM					
	3	Ramgarh AWC	Bhuri Devi	11 km	22 mins		3.12 PM	3.12 PM					
	4	Chhoti Sarwa Pri School	Sheela Rooplal	14 km	30 mins		3.02 PM	3.02 PM					
	5	Bijori Kalan AWC	Shashi Kiran	17 km	35 mins		3.00 PM	3.00 PM					
Garhi town	1	Garhi Rural Hospital	Mita Sharma	1 km	10 mins	8.45 AM			ANM Collects				
	2	Yusufpura AWC	Sona Lohar	2 Km	15 mins								
Signature of Block Medical Officer:										Signature of IO/ICC:			

Remember

To do this:

- Select a site that is as cool as possible, preferably inside a room. If a room is not available, carry out immunization in the shade and not in direct sun.
- Vaccines (OPV, BCG and measles after reconstitution) must be kept on an ice pack or in a cup of ice during the session.
- Never place freeze sensitive vaccines vials on ice pack.
- Open the carrier only when necessary.
- Remove vaccine and diluents from the vaccine carrier, ONLY when you need it.
- Take out only one vial of vaccine from the carrier at a time. Do not take the second vial from the carrier until it is needed.
- Secure the lid tightly after opening as soon as possible.
- When the session is completed, return all vials, open and unopened and immunization waste through Alternate Vaccine Delivery system.

7.7 Improving Vaccine Use and Reducing Wastage

Although a certain amount of wastage of vaccines and other supplies are expected at all level of the program, indeed inevitable, but through good vaccine management practice it can reduced. The table given below lists the types of the wastages commonly encountered both avoidable and unavoidable in open and unopened vials.

Wastage	Unopened vials	Opened vials
Avoidable wastage	<ul style="list-style-type: none">• Unused & unopened vials thrice return from session site• Expiry• VVM in discard stage• Breakage loses	<ul style="list-style-type: none">• Over supply• Suspected contamination
Unavoidable wastage		<p>Discard of</p> <ul style="list-style-type: none">• Remaining doses at end of the session• Reconstituted vaccines to be discarded after 4 or 2 hrs depending on vaccines

Contingency Plans for Emergency Situations – Alternative Storage Arrangement



CONTINGENCY CUM EMERGENCY PLAN FOR VACCINE HANDLERS
NAME OF THE CUM: S.R.POMV - REGIONAL VACCINATION SURVEILLANCE
PREPARED: NOVEMBER 2016

What to do:
1. In case of any emergency, the person in charge should immediately inform the District Health Officer (DHO) and the State Health Officer (SHO).
2. The person in charge should immediately inform the State Health Officer (SHO) and the District Health Officer (DHO) about the emergency.

Who will do:
1. The person in charge of the vaccine storage chest.
2. The person in charge of the vaccine storage chest.

What to do:
1. In case of any emergency, the person in charge should immediately inform the District Health Officer (DHO) and the State Health Officer (SHO).
2. The person in charge should immediately inform the State Health Officer (SHO) and the District Health Officer (DHO) about the emergency.

In case of D.H. Off breakdown, immediately inform:

Designation	Name	Phone No.	Mobile No.
S.R.M.O.	Dr. Sant J. Kamath	0682250218	9437255410
Senior Cold Chain In-charge	Mr. Avinash M. Mokal	0682250218	9437867499
Vaccine and Cold Chain Handler at the Centre	Mr. Ananta Madhav Behera	0682250218	9955664929

8

Contingency Plans for Emergency Situations – Alternative Storage Arrangement

The Cold Chain is dependant on electrically operated machines on which one cannot depend completely. However, acute problems are unlikely if the equipment are maintained well and used with proper care. Uninterrupted and steady electrical supply is a major requirement for good performance of equipment.

When the vaccines cannot be stored at the appropriate temperature due to breakdowns in equipment (WIC/ILR/DFs)/electricity failure, alternative storage arrangements have to be made in advance to ensure that this contingency is taken care of. The alternative storage locations will have to be identified in advance. Suitable posters should be designed and pasted on machines with clear instructions in local languages on how to handle such emergency situations.

Steps to prepare contingency plans

Contingency plans for emergency situations specially electricity failure must be prepared in advance and appropriate sanctions taken so that no time is lost during an emergency. This will help you face such eventualities without any element of panic.

The following steps should be taken:

- Identify most suitable alternative arrangement for each equipment.
- List out the resources and actions involved and the persons identified to carry out the same.
- Make aware all concerned, of the requirements and the activities that may be necessary during emergency and educate/train them accordingly.
- Identify more than one alternative for assurance (stand by arrangement).
- Periodically check availability of the identified requirement and awareness of the persons concerned.

Figure 40: Emergency plan for vaccine store

Based on the situation in your CHC/PHC prepare a plan for safely storing vaccines during equipment breakdown or long electricity failure

(Prepared on : _____)

Name of PHC/CHC: Ramgarh

When to act:

1. Power failure for more than 18 hrs.
2. Major Break down of ILR/DF
3. _____

Who will act (Name and Designation):

1. Dr. R.K. Yadav, MOIC, PHC, Ramgarh
2. Shri S.K Gupta, MPW, PHC, Ramgarh

What to do (Recommendation Action)

Equipment	Action
ILR	<ol style="list-style-type: none"> 1. Shift the vaccines in cold boxes with conditioned Ice packs. 2. Arrange shifting of vaccine to the nearby PHC Raniganj and store in ILR (If cold chain capacity available), if not 3. Contact CHC, Shamgarh for arranging the cold chain space and arrange shifting.
DF	<ol style="list-style-type: none"> 1. Shift the Ice packs in to cold boxes, if extra cold box available, after shifting of vaccine from ILR. 2. Contact Mr. Bhrura ice factory to get ice pack freezed.

Incase of ILR/DF under break down for long period, immediately inform to:

Organization	Name	Designation	Phone no.
State Government	Dr. S.C Purohit	DIO	924067235
State Government	Shri C.P. Sharma	Ref. Mechanic	9867543200
State Government	Shri R.L. Sharma	State CCO	9456743252
M/s Modi Refrigeration	Shri O.P. Singh	Technician	9870965489

Record details of breakdown in inventory register and UIP performance report.

Table 4: Alternatives for emergency situations

Failure	Equipment	Primary health centre	Districts
Power failure of longer duration (more than 6-8 hours)	ILR	Observe temperature of vaccines. If it reaches 8oC, transfer and store them in cold boxes with conditioned ice-packs from the freezer.	Similar to PHC.
	Freezer	If vaccines are not preserved in freezer, no action required. Otherwise transfer them to a cold box.	If vaccines preserved in freezer, transfer them to cold box and preserve with frozen icepacks or commercial ice in polythene bags.
Equipment Breakdown (Select suitable alternative indicated)	ILR	<ol style="list-style-type: none"> Store in cold boxes with conditioned icepacks. Transfer to domestic refrigerator if available in the vicinity. Transfer to any nearby PHC or other departments vaccine storage facility if available. 	<ol style="list-style-type: none"> Store in cold box with conditioned icepacks. Transfer to other ILR or Refrigerator available. Transfer to any other vaccine storage facility available.
	Freezer	<ul style="list-style-type: none"> Dispatch vaccine using commercial ice, if available locally. Freeze icepacks in domestic refrigerator/s or in commercial ice factory, if available. Collect required quantity of frozen icepacks from nearby PHC in cold boxes just on the day or a day ahead of vaccine distribution. 	<ul style="list-style-type: none"> Store vaccine in ILRs or refrigerator available. Dispatch vaccines-similar way as for PHC. Ask recipient of vaccine to bring frozen icepacks while coming for collection.
	Voltage Stabilizer	<ul style="list-style-type: none"> Preserve vaccine as above. Disconnect the stabilizer and obtain replacement immediately from District/ Regional HQ and reconnect. 	Replace from float assemblies immediately from District/ Regional HQ stock.

Responsibilities of Cold Chain Handlers and Medical Officer



9

9.1 Responsibilities of Cold Chain Handlers

9.2 Responsibilities of Medical Officer of PHC/CHC

9.1 Responsibilities of Cold Chain Handlers

1. Support the MO I/C in UIP implementation, focusing on improved management of the cold chain inclusive of basic preventive maintenance of cold chain equipments, vaccine & logistics management (goods clearance, elimination of overstocking and stock outs of vaccine) and injection safety including proper waste disposal.
2. Ensure monthly reporting of Immunization data including vaccine usage, VPD and AEFI cases as per GOI guidelines. Assist in drafting of Monthly and annual progress report.
3. Assist MO I/C to conduct periodic programme reviews and undertake action on operational procedures specifically in areas of cold chain and logistics affecting the implementation and management of the UIP.
4. Maintaining of accurate stock records and periodic review of supply requisitions.
5. Assist MO I/C in preparing annual vaccine forecasts of the PHC/CHC.
6. Assist MO to micro plan for adequate & timely supply of vaccines & logistics through alternate vaccine delivery mechanism.
7. Recording of temperature in the Temperature Record Book twice daily as per guidelines.
8. Identification of emergency situation and implement contingency plan.
9. Any other immunization related work as specified by Medical Officer.

9.2 Responsibilities of Medical Officer of PHC/CHC

1. Provide technical guidance to the PHC/CHC level staff on cold chain management and conduct periodical evaluation of cold chain for the purposes of repair and replacement.
2. Undertake field visits to session sites and provide supportive supervision to health care workers to maintain proper cold chain for vaccines, logistics and waste disposal.
3. To provide feedback/refresher trainings to workers on issues related to cold chain & vaccine logistics especially during monthly meeting.

Chapter 10

Facilitator's Guide



10

10.1 Introduction

10.2 Suggested Guidelines for Cold Chain Handlers Training

10.3 Pre-Training Preparation Check List

10.4 List of Equipments and Supplies Required During Training

10.5 Tentative Programme for Vaccine & Cold Chain Handlers Training (Use Session Sequence as per Book Chapter)

10.6 Conducting Training Sessions

10.7 Role Play – 1 (Script)

10.8 Pre and Post Evaluation Questionnaire

10.1 Introduction

This facilitator's guide is meant for imparting training to vaccine and cold chain handlers with the aim to improve knowledge and skill in providing better immunization services.

10.2 Suggested Guidelines for Cold Chain Handlers Training

Duration of training	2 working days
No. of trainees per batch	15
Venue	District Head Quarter/ANM Training Centre
Facilitators	SEPIO/CCO/T.A Cold Chain/DIO/ANMTC trainer/ Identified cold chain technician
Co-Facilitator	Cold chain Technician of the district
No. of facilitator	One facilitator for each group of 4-5 trainees
Methodology	Power point presentations, Group discussions, Demonstration, Hands on training, Role play

10.3 Pre-Training Preparation Check List

1. Finalize the venue for training and date and time allocation for various sections of the training workshop.
2. Identify at least 3 facilitators per batch, one of them act as lead facilitator cum training coordinator, and one as co-facilitator.
3. Confirm nomination of participants.
4. Arrange teaching aids like black/white board, chalk, Flip charts, OHP/LCD, transparencies, marker pens etc. for various sessions.
5. Arrange stationeries and modules.
6. Arrange accommodation, refreshment, lunch and payments.

7. Arrange equipments for demonstrations.
8. A facilitators meeting should be arranged one day before the start of training to ensure availability of all logistics, equipments, teaching aids and discussion on training methodology.

10.4 List of Equipments and Supplies Required During Training

1.	Registration form	
2.	Green and pink chart paper	
3.	Flip charts	
4.	Hand outs of Pre and post training evaluation	
5.	ILR 140 liter – Latest model with microprocess control panel	1 no.
6.	DF 140 liter – Latest model	1 no.
7.	Voltage stabilizers	2 nos.
8.	Cold box 20 liter	1 no.
9.	Vaccine carrier	1 no.
10.	Ice packs	120 nos.
11.	Stem Alcohol Thermometer	1 no.
12.	Mixed antigen vaccine cartoons of different Expiry dates	30 nos.
13.	Diluents BCG/Measles	5 each
14.	OPV in different stages of VVM	4 nos.
15.	DPT vial Frozen and samples for shake test	3 each
16.	Polyethylene bags for vaccines	20 nos.
17.	Temperature record book	1 no.
18.	Stock register	4 nos.
19.	Vaccine and logistics indent book	4 nos.
20.	Screw driver	1 no.
21.	Test board lamp	1 no.
22.	Plug (ISI marked)	1 no.
23.	Plug (Non-ISI marked)	1 no.
24.	Role play scripts	

10.5 Tentative Programme for Vaccine & Cold Chain Handlers Training (Use Session Sequence as per Book Chapter)

Day-1		
Time	Activity	Methodology
08.00 – 08.30	Registration	–
08.30 – 8.40	Inauguration	
8.40 – 9.15	Pre-evaluation test & expectation of participants	Questionnaire & flip charts
9:15 – 9:30	Overview of UIP	Presentation
9.30 – 10.00	Introduction and formation of 3 Groups of 4-5 participants with one facilitator in each group	Lead facilitator will form the group
10.00 – 11.00	Introduction of vaccines, cold chain system, Heat and freeze sensitivity and monitoring of cold chain	<ul style="list-style-type: none"> – Presentations, – Demonstration of all vaccines having VVM at different stages, Frozen vaccines
11.00 – 11.15	Tea Break	
11.15 – 12.00	Electric Cold Chain equipments (WIF/WIC, ILR, DF), its components, storage of vaccine and loading of Ice packs in ILR/DF/Domestic refrigerator and installation of ILR/DF	Introduction of topic by Facilitator followed by Demonstration of ILR and D.F, domestic refrigerator (if available)
12.00 – 12.30	Automatic voltage stabilizers, control panel of ILR/DF and their functions	Presentations and demonstration
12.30 – 13.30	Hands on practice (Group wise) 1. Loading of vaccines in ILR 2. Loading of Ice packs in DF 3. Connections of voltage stabilizers, measuring the input and output voltage	Group work
13.30 -14.30	Lunch Break	
	Warm up exercise (5 min)	
14.35 – 15.00	Non-electric cold chain equipment (Cold box, vaccine carrier, Ice packs), Conditioning of Ice Packs	Introduction of topic by Facilitator followed by Demonstration
15.00 – 16.00	Hands on practice (Group wise) 1. Preparation of Cold box in emergency 2. Preparation of vaccine carrier 3. Installation of ILR	Group work
16.00 – 16.15	Tea Break	
16.15 – 16.30	Video film on cold chain maintenance	By lead facilitator
16.30 – 17.00	Temperature monitoring, introduction of data loggers	Presentation on importance of tempt. Monitoring and various devices. Followed by demonstration of each device
17.00 – 17.30	Group discussions and summary of day	By lead facilitator

Day-2		
Time	Activity	Methodology
08.00 – 8.30	Recap of 1st Day	
08.30 – 08.45	Transportation of vaccine	Presentation
08.45 – 09.15	Maintenance of cold chain equipments, preventive maintenance and trouble shooting	Presentations/Demonstration
09.15 – 10.15	Group discussions on field problems on cold chain maintenance	Flip charts
10.15 – 11.15	Vaccine management, Storage and distribution of vaccines	Group reading
11.15 – 11.30	Tea Break	
11.30 – 12.30	Hands on practice by each group 1. Shake test 2. Defrosting (demonstration only) 3. Trouble shooting	Group work
12.30 – 13.30	Contingency plan and responsibilities	Group reading and group work
13.30 – 14.30	Lunch Break	
	Warm up exercise (5 min)	
14.35 – 15.30	Hands on practice by each group 1. Filling of stock register 2. Filling of indent form for requirement of PHCs 3. Temperature recording in temperature record book	Group work
14.45 – 15.45	Role play (as per script) and discussions	By lead facilitator
15.45 – 16.00	Tea Break	
16.00 – 16.15	Post evaluation	Questionnaire
16.15 – 17.15	Open discussions and conclusion	By lead facilitator

10.6 Conducting Training Sessions

Day – 1	
Time 30 minutes Training Aids 1. Module 2. Stationary registration form	Registration <ul style="list-style-type: none"> • Distribute modules, stationary , bag etc. • Register participant • Make note nos of nominated participants not attended
Time 10 minutes Training Aids;	Inauguration and expectations <ul style="list-style-type: none"> • Timely inauguration: Status of cold chain in the district and need of training. (ten minutes)
Time 35 minutes Training Aids; 1. Pre-test questionnaires Red and Pink charts 2. Flip charts	Distribute the questionnaire to be filled by participants and collect after 15 minutes <ul style="list-style-type: none"> • Ask the participants to write their expectations and apprehensions from the training workshop (ten minutes). Write participants response on flip charts (ten minutes).
Time 15 minutes Chapter 1 Training Aids; overview of UIP	Power point presentation on Overview of UIP Presentations to cover <ol style="list-style-type: none"> 1. UIP in the country 2. Vaccine preventable diseases 3. National immunization schedule
Time 60 minutes Chapter 2. Training Aids: 1. LCD projector 2. Presentations 3. All vaccines at different stages 4. Frozen vaccine	Introduction of cold chain system, Heat and freeze sensitivity and monitoring of cold chain. <ol style="list-style-type: none"> 1. Brief the participants about the importance of temperature monitoring, cold chain system, Heat sensitivity and freeze sensitivity. 2. Describe the monitoring of the cold chain through presentations.
Time 45 minutes Chapter 3 Training Aids; 1. ILR 2. DF 3. vaccines cartoons 4. Ice packs 5. Domestic ref. if available	Electric Cold Chain equipments (WIF/WIC, ILR, DF), its components, storage of vaccine and loading of Ice packs in ILR/DF/Domestic refrigerator, solar equipments. <ol style="list-style-type: none"> 1. Brief the function of WIF and WIC. 2. Demonstrate ILR, Deep freezer, its components, capacity, hold over time and other specifications as per the hand book. 3. Brief and demonstrate the storage of vaccines in ILR and loading of Ice packs in DF. 4. Brief about solar equipments.
Time 30 minutes Chapter 3 Training Aids; 1. Voltage stabilizers 2. ILR 3. DF	Automatic voltage stabilizers & control panel of ILR/DF Brief the function of voltage stabilizer, its components and electric connections. Brief the function of control panel of ILR and DF.
Time 60 minutes Training Aids; 1. ILR 2. DF 3. Voltage stabilizers 4. Vaccines cartoons of different expiry dates 5. Ice packs 6. Screw driver 7. Test board with lamp 8. Line plug	Hand on practice: The participants will be divided in three groups and each group will do three hands on practice by rotation. <ol style="list-style-type: none"> 1. Loading of vaccines in ILRs:- Take cartoons of vaccine and mark them different dates of receipt at PHC- allow participants to store cartoon in ILRs. Let it store as it is, when second group comes, ask them to check it and get them note down the mistakes and rearrange it. The same will be repeated for third also. 2. Loading of D/F by ice packs: Give sixty ice packs to the group and ask them to follow the procedure of freezing the ice packs including filling of water. Follow the same procedure for next group as done in the case of loading of vaccines. 3. Connections of voltage stabilizers, measuring the input and output voltage: Give voltage stabilizer, one line plug and one screw driver to the participants and ask them to connect power with stabilizer. Out put may be connected to test board and lamp. Ask them to note down the input and out voltage, check the earthing in the socket. The same will be repeated with other groups also.

<p>Time 25 minutes Chapter 4 Training Aids;</p> <ol style="list-style-type: none"> 1. Cold box 2. Vaccine carrier 3. Stem Alcohol thermometer 4. ILR 5. DF 	<p>Non-electric cold chain equipment (Cold box, vaccine carrier), and their functions, and installation of ILR/DF Brief function and type of cold box, vaccine carrier, Ice pack and installation of ILR/DF.</p> <ol style="list-style-type: none"> 1. Make three groups of 4-5 participants with one facilitators to each group. 2. One facilitator will demonstrate cold box its maintenance. 3. Second facilitator will demonstrate vaccine carriers, its maintenance. 4. Third facilitator will demonstrate installation of ILR/DF. <p>After every 5 minutes the groups will change their positions.</p>
<p>Time 60 minutes Training Aids;</p> <ol style="list-style-type: none"> 1. ILR 2. Cold box 3. Vaccine carrier 4. Ice packs 5. Vaccines cartoons 6. Polyethylene bags 7. Screw driver 	<p>Hands on practice: The participants will be divided in three groups and each group will do six hands on practice by rotation.</p> <ol style="list-style-type: none"> 1. Preparation of cold box: Give 60 ice packs, and cartoons of vaccines to the participants and allow them to keep in cold box. Repeat it for other group also. 2. Preparation of vaccine carries: Give one vaccine carrier, and 500 doses of vaccines with ice packs. Ask the Group to prepare the vaccine carrier for out reach area. The participants should do the conditioning also (demonstration). Repeat it for other groups also. 3. Keep ILR away from the socket point and ask the group to demonstrate the installation of the ILR. Two participants will do the work and others will note down the steps. The steps will be shared with the combined group.
<p>Time 15 minutes Training Aids;</p> <ol style="list-style-type: none"> 1. Video CD 2. LCD projector 	<p>Video film show on cold chain maintenance.</p>

<p>Time 30 minutes Chapter 4 Training Aids</p> <ol style="list-style-type: none"> 1. LCD projector 2. Stem thermometer 3. Dial thermometer 4. Electronic data logger 5. Freeze indicator 6. Temperature record book 	<p>Temperature Monitoring and introduction of data loggers: Power point presentation on importance of temperature monitoring Demonstrate all temperature monitoring devices, their function and temperature reading and recording.</p>
---	--

Day – 2	
<p>Time 15 minutes Chapter 5</p>	<p>Introduction of vaccine van and transportation of vaccine – power point presentation as per chapter 6.</p>
<p>Time 30 minutes Chapter 6 Training Aids</p> <ol style="list-style-type: none"> 1. LCD projector 2. Presentation 3. ILR 4. DF 5. Stabilizer 	<p>Maintenance of cold chain equipments, preventive and trouble shooting.</p> <ul style="list-style-type: none"> • Brief about the sickness rate, response time and breakdown time, daily, weekly and monthly checkup, and preventive maintenance. • Demonstrate defrosting. • Demonstrate minor trouble shooting as per the hand book.
<p>Time 60 minutes Training Aids</p> <ol style="list-style-type: none"> 1. Exercise hand out 	<p>Group discussions on field problem:</p> <ol style="list-style-type: none"> 1. Divide participants in groups, ask them to discuss and write down the field problems in maintenance of cold chain and possible remedies. 2. Group leader will present the discussions points of his group and discuss the possible remedies.
<p>Time 60 minutes Chapter 7 Training Aids</p> <ol style="list-style-type: none"> 1. Training module 	<p>Vaccine Management, Storage and distribution of vaccines.</p> <ul style="list-style-type: none"> • Divide in groups and do group reading of chapter 8 with facilitators. • Exercise will be given to calculate vaccine and AD syringe requirement for a PHC on given target population (Q.No. 10 of Pre and post evaluation questionnaire.

<p>Time 60 minutes Training Aids 1. Sample and frozen vial of DPT/DT/TT 2. ILR 3. DF</p>	<p>Hands on practice: Each practice will be of 15 minutes per group. Divide in to three groups with facilitators:</p> <ul style="list-style-type: none"> • One group will do the shake test. • Second group will do the defrosting. • Third group will do the trouble shooting. The facilitator will create minor problem and participants are required to identify the problem and shoot out.
<p>Time 60 minutes Chapter 8 Training Aids 1. Training module</p>	<p>Contingency plan and responsibilities:</p> <ul style="list-style-type: none"> • Divide in groups and do group reading of chapter 9 with facilitators. • Ask the participant to make contingency plan for his district/PHC.
<p>Time 55 minutes Training Aids 1. Thermometer 2. Blank indent form 3. Blank stock register form 4. Temperature record book</p>	<p>Hands on practice: Divide in to three groups with facilitators, each practice will be of 15 minutes per group. 10 minutes for discussions. For stock register and indent data will be provided by the facilitator:</p> <ul style="list-style-type: none"> • The first group will fill up the indent form. Facilitator will provide data and ask participants to fill up the indent form. • Second group will fill up the stock register. • And third group will record the temperature of ILR in the temperature record book.
<p>Time 60 minutes Training Aids; 1. ILR 2. DF 3. Vaccines 4. Vaccine carrier 5. Cold box 6. Vaccines 7. Ice packs 8. Polyethylene bags</p>	<p>Role Play:</p> <ul style="list-style-type: none"> • Take two participants and ask them to play the role as per the script. • Ask other participants to note down the mistakes. • Discuss observations of the participants. • Take other two participants for role play with no mistakes. • Discussions on role play.

10.7 Role Play – 1 (Script)

Number of participants: 2

Characters:

1. Cold Chain Handler posted at PHC
2. Alternate vaccine delivery person

Training Aids:

1. Deep Freezer
2. ILR
3. Vaccine carriers
4. Cold box
5. Vaccines
6. Ice packs
7. Polythène bag
8. Stock registrar

Scene: In a PHC, the cold chain handler is sitting on a cold box. AVD comes with two vaccine carriers to collect vaccines for immunization day.

Handler: Come Mr. Ramprashad, How are you.

AVD: I am fine sister, may I have vaccines for today.

Handler: Yes, have you micro-plan of your area with you.

AVD: No sister but today we have only two sessions one in Ramgarh and other in Premganj, I require DPT, Measles and OPV only for Ram garh and one vial each for Prem ganj. Sister of Ramgarh told me that there is no child for BCG for today and she is having TT in her refrigerator which could not used during last session.

Handler: O.K. Take your self from ILR, I am issuing one each vial for your sub-center in my record.

AVD takes out frozen ice packs from deep freezer and keeps them directly in to vaccine carriers. After that he takes vaccines from ILR and keeps in to the vaccine carriers. he closes the carrier walks out.

AVD: OK sister, I have taken eight ice packs and vaccines and thanks.

Role Play – 2 Script:

Scene: In a PHC, the cold chain handler is sitting on a chair. AVD comes to collect vaccines for immunization day.

Handler: Come Mr. Ram prashad, How are you.

AVD: I am fine sister, may I have vaccines for today.

Handler: Yes, have you micro-plan of your area with you.

AVD: No sister but today we have only two sessions one in Ramgarh and other in Premganj, I require DPT, Measles and OPV only for Ram garh and one vial each for Prem ganj. Sister of Ramgarh told me that there is no child for BCG for today and she is having TT in her refrigerator which could not used during last session.

Handler: No. Please collect a copy of micro-plan from PHC and check your requirement. You should take all vaccines as per your micro-plan and ask ANM never use TT vaccines which is lying in refrigerator as there might be a chance of breakage of cold chain in her domestic refrigerator.

Handler: How many vials you require of each vaccine.

ANM: One vial each of DPT, DT, TT, OPV and BCG and two vials of measles for Ram garh and one vial each for Prem ganj.

Handler: O.K. Come to the cold chain room.

In the cold chain room handler unlocks the deep freezer and ILR.

Handler takes out frozen ice packs from deep freezer and keeps them on table for conditioning. After few minutes she checks for conditioning of ice packs and put them in to vaccine carrier. She takes out the vaccines as per requirement, notes down the expiry dates and batch numbers. DPT, DT, TT and Diluents and all vaccines keeps in polyethylene bag and bag is placed in vaccine carrier. She closes the ILR and deep freezer and locked.

ANM: OK sister, thanks.

Handler: OK, return all unused vials in the evening.

AVD goes out.

10.8 Pre and Post Evaluation Questionnaire

Q. No.1: Arrange the vaccines as per heat sensitivity: Keep most heat sensitive vaccine at top

- | | |
|---|---------|
| 1. DPT | a.----- |
| 2. Hept. B | b.----- |
| 3 Measles (Before & after reconstitution) | c.----- |
| 4. OPV | d.----- |
| 5. BCG (after reconstitution) | e.----- |
| 6. TT | f.----- |
| 7. BCG (before reconstitution) | g.----- |

Q. No. 2 Which vaccine is most freeze sensitive?

- a. BCG b. DPT c. TT d. Hep. B

Q. No.3 How many doses of mixed antigen can be stored in 144 liter ILR?

- a) <7000 b) 7000-9000 c) 9000-11000 d) 11000-13000

Q. No. 4 If green light in an ILR glowing, it indicates that:

- a. ILR is working well
b. Power is available in ILR
c. Vaccine temperature is with in safe range
d. All of above

Q. No. 5 Red light in Deep freezer indicates that:

- a. D/F is OK
b. Temperature is not in range
c. D/F is not working

Q. No.6: Which of the vaccines should be stored at the top section of the ILR basket (you may give more than one answer):

- a. BCG b. DPT c. Measles
d. OPV e. TT f. Hept. B

Q. No. 7 What else can be safely stored with vaccines in the ice lined refrigerator?

- a. Food and drinks
b. Other biological which need refrigeration
c. Unfrozen ice packs
d. Other drugs

Q. No.8. Which days in this ILR temperature chart are in the UNSAFE range?

(Tick all that apply)

S.No.	Date	At 10.00 AM	At 4.00 PM
A	14.04.08	+3	+5
B	15.04.08	+2	+2
C	16.04.08	(-)3	0
D	17.04.08	+2	+2
E	18.04.08	+2	+5
F	19.04.08	+7	+7
G	20.04.08	+9	+12

Q. No.9. On 6th May 2009 you have stock of DPT vaccines in your ILR as under:

Lot No.	Received from	Quantity	Date of expiry	Date of receipt	VVM status
1	District	10 vials	31.08.09	11.04.09	Usable
2	From Block PHC	3 vials	31.06.09	20.04.09	Usable
3	From out reach session site as returned un opened vaccine (first time)	1 vial	30.09.09	28.04.09	Usable
4	District	5 vials	31.08.09	15.03.09	Usable
5	District	2 vials	30.09.09	01.03.09	Usable but Darker

You are required to issue 5 vials on 6th May and 7 vials on 13th May 2009, to sub-centers, which vaccines will you issue on 6th and 13th respectively.

Ans:

Date	Vial Qty.	Lot No.	Vial qty.	Lot No.	Vial qty.	Lot No.	Total Vials
6.05.09							
13.05.09							

Q. No. 10:- A PHC has a target of 1200 infants and 1320 pregnant women for the year 2009-10. Calculate vaccine and AD syringes requirement for one month.

Ans:-

BCG ----- vial

DPT ----- vial

Measles ----- vial

TT ----- vial

OPV ----- vial

0.1 ml AD syringes ----- nos

0.5 ml AD syringes ----- nos

5 ml Mixing syringes ----- nos

Pre and post evaluation answers

Q. No. 1

- a. BCG after reconstitution
- b. OPV
- c. Measles before and after reconstitution
- d. DPT
- e. BCG before reconstitution
- f. TT
- g. Hepatitis B

Q. No. 2 d

Q. No. 3 d

Q. No. 4 b

Q. No. 5 b

Q. No. 6 b & f

Q. No. 7 c

Q. No. 8 c & g

Q. No. 9

Date	Vial Qty.	Lot no.	Vial qty.	Lot no.	Vial qty.	Lot no.	Total vial
6.05.09	2	5	1	3	2	2	5
13.05.09	1	2	5	4	1	1	7

Q. No. 10

BCG	17 vial
DPT	84 vial
Measles	34 vial
TT	64 vial
OPV	34 vial
0.1 ml AD syringes	138 nos
0.5 ml AD syringes	1767 nos
5 ml Mixing syringes	56 nos.

References

1. Ministry of Health & Family Welfare, Government of India. Immunization Handbook for Medical Officers. New Delhi: Dept. Health & Family Welfare, Govt. of India, 2009.
2. Ministry of Health & Family Welfare, Government of India. Cold Chain: Management for Vaccine Handler. New Delhi: Dept. Health & Family Welfare, Govt. of India, 2003.
3. Ministry of Health & Family Welfare, Government of India. Manage Cold Chain Module III, Manage Cold Chain. New Delhi: Dept. Health & Family Welfare, Govt. of India, 2001.
4. Directorate of Health & Family Welfare, Government of UP. Hand book for Cold Chain Handlers. Lucknow: 2004.
5. Directorate of Health & Family Welfare, Government of Rajasthan. Hand book for Cold Chain Handlers. Jaipur.
6. Ministry of Health & Family Welfare, Government of Bihar. Hand book for Cold Chain Handlers. Patna.

